

AVISO

Esta guía rápida es un resumen del manual de instalación completo. Dicho manual contiene advertencias de seguridad y otras explicaciones que deben ser tenidas en cuenta. Puede descargar el manual de instalación en el apartado "Descargas" de la web de Erreka: <http://www.erreka-automation.com>

Elementos de la instalación completa

Cableado eléctrico

- A: Alimentación general
- B: Lámpara destellante
- C: Fococélulas (Tx / Rx)
- D: Selector de llave

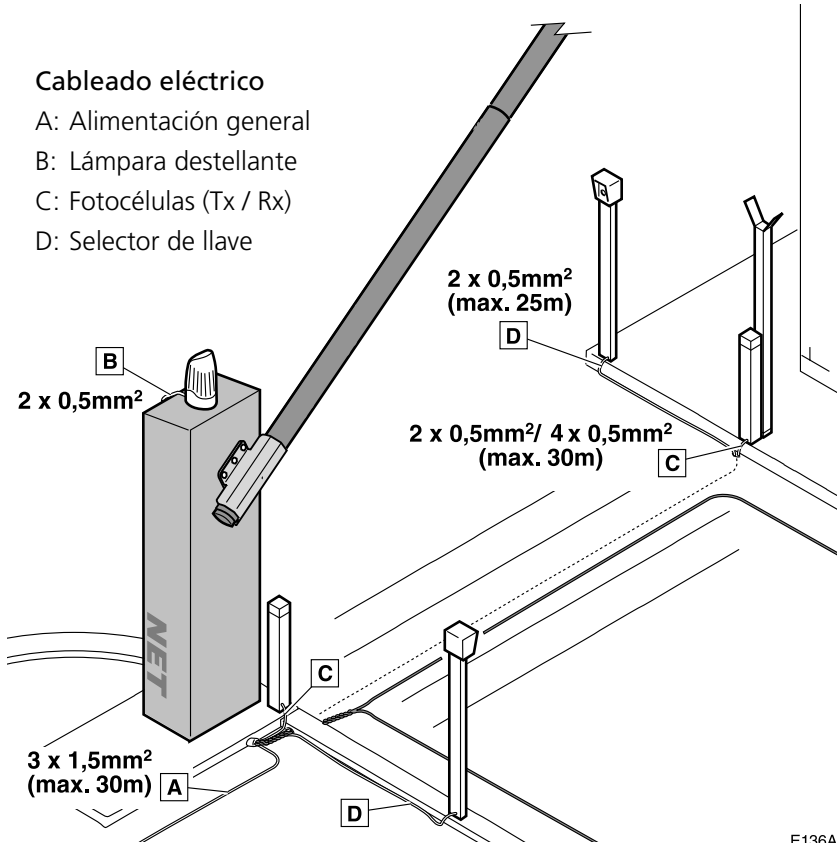

E136A

Desbloqueo

⚠ El desbloqueo debe realizarse con precaución. Si la barrera no está equilibrada o el brazo no está montado, el muelle interno puede provocar un desplazamiento violento.

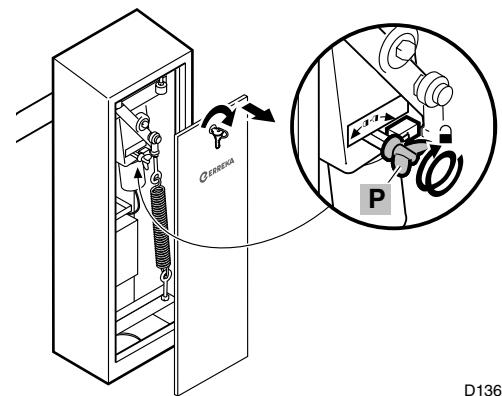

D136A

Desbloqueo (accionamiento manual): gire la palomilla (P) hacia la derecha hasta el tope.

Bloqueo (accionamiento motorizado): gire la palomilla (P) hacia la izquierda hasta conseguir el bloqueo.

Montaje del brazo

La barrera se suministra para montaje a la derecha. Si desea montarla a la izquierda, antes de montar el brazo realice el "Cambio de lado" (vea la página siguiente).

- 1 Bloquear el accionador y montar el primer tramo.
- 2 Desbloquear el accionador y bajar manualmente el brazo.
- 3 Bloquear el accionador y montar el segundo tramo.

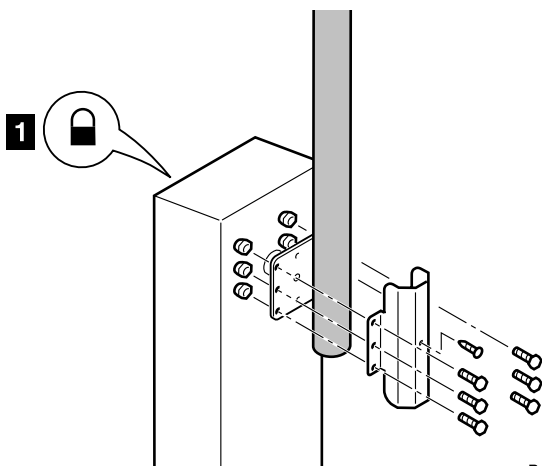

P136C1

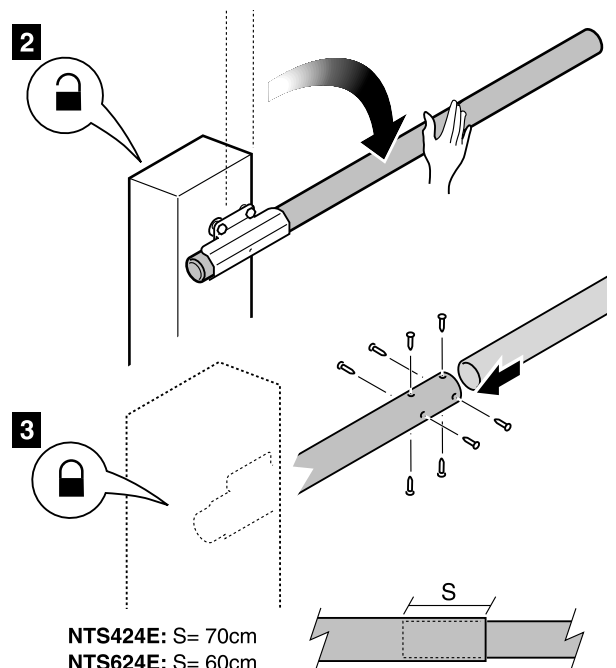

NTS424E: S= 70cm
NTS624E: S= 60cm

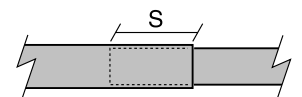

P136C2

Cambio de lado

Barrera derecha

Barrera izquierda

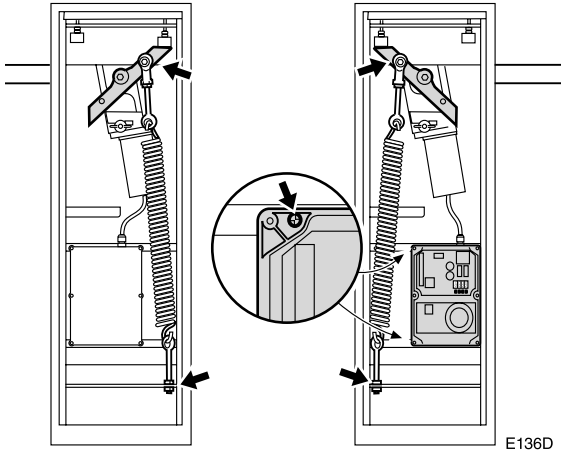

E136D

Equilibrado

➡ **PARA UN CORRECTO FUNCIONAMIENTO, ES IMPRESCINDIBLE EQUILIBRAR LA BARRERA.**

- Desbloquee el accionador y tense el muelle hasta que la barrera quede equilibrada a 45°.

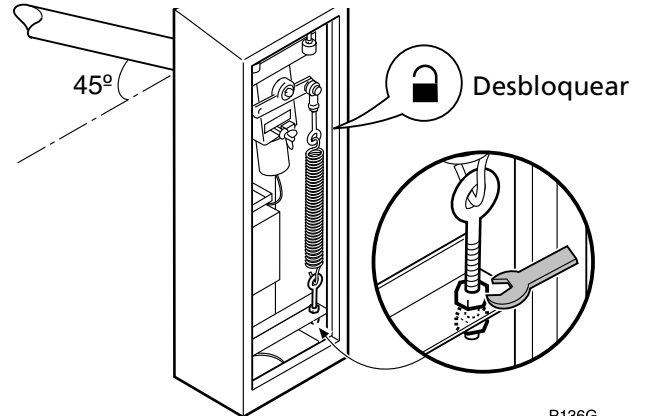

P136G

Conexión general

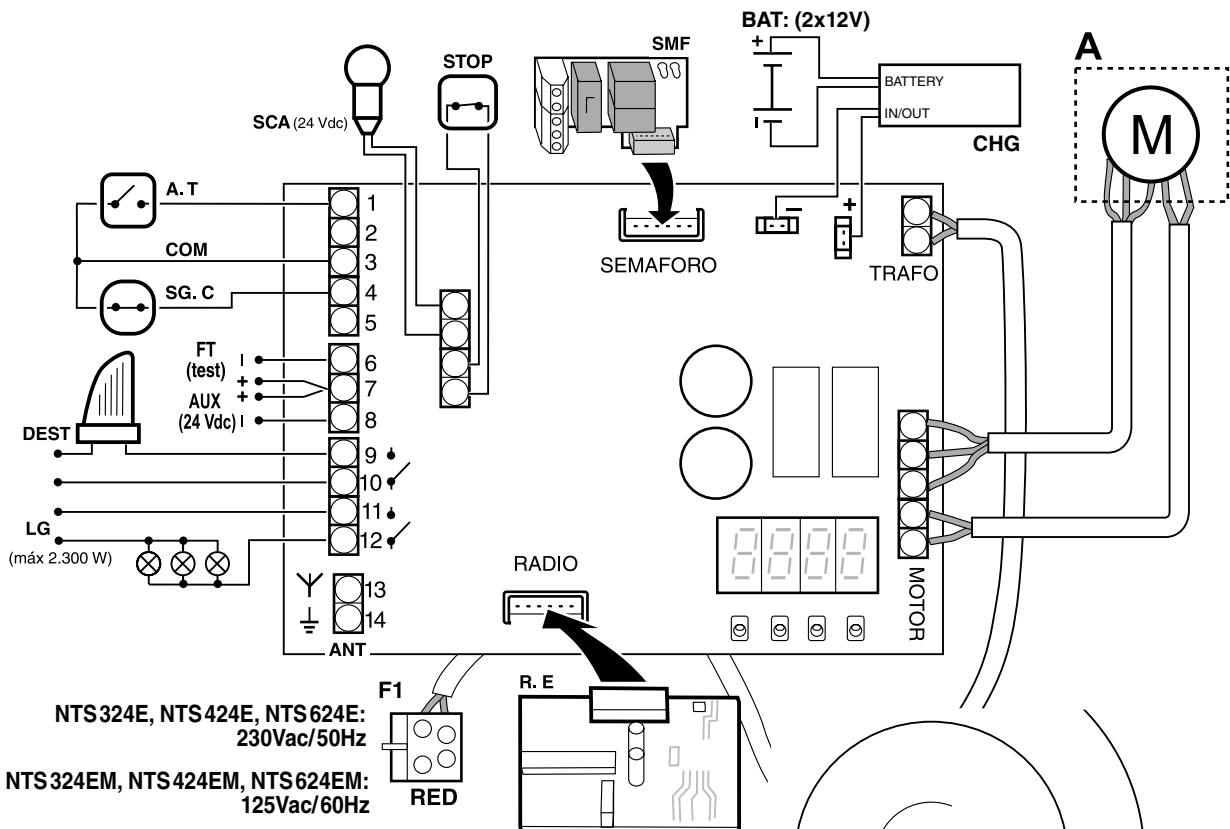

P136F

Indicaciones del display

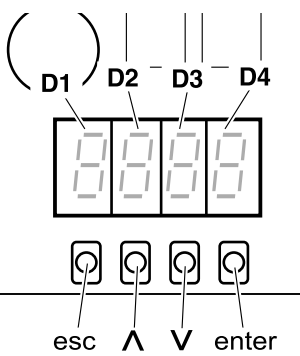

D1 y D2:

CL (fijo)	Barrera cerrada
CL (parpadeando)	Barrera cerrando
OP (fijo)	Barrera abierta
OP (parpadeando)	Barrera abriéndose
XX (cuenta atrás)	Barrera en espera
STOP	Accionador desbloqueado
PA (fijo)	Pausa (maniobra no finalizada)
RS (fijo)	Barrera buscando posición de cierre

D3 y D4:

CS	Dispositivo de seguridad en cierre activado
E I	Encoder motor detenido
F I	Límite de fuerza rebasado
BA	Batería en funcionamiento
Ft no	Fotocélulas defectuosas (testeo)

M136C

Cambio del sentido de giro (C I)

Esta operación sólo es necesaria si la barrera, al hacer reset (r5), se abre en vez de cerrarse.

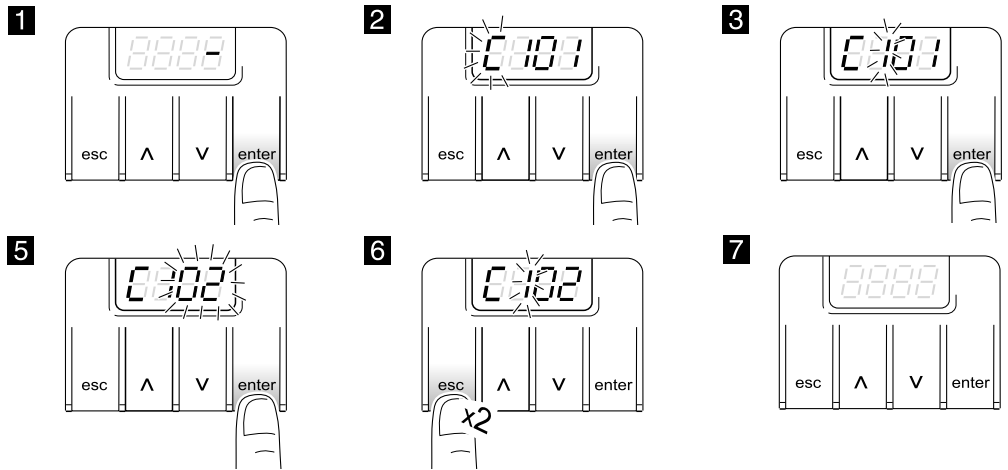

P58G

Grabación del código de radio, P I (sólo con receptor RSD)

Si utiliza un receptor distinto al RSD, consulte sus propias instrucciones.

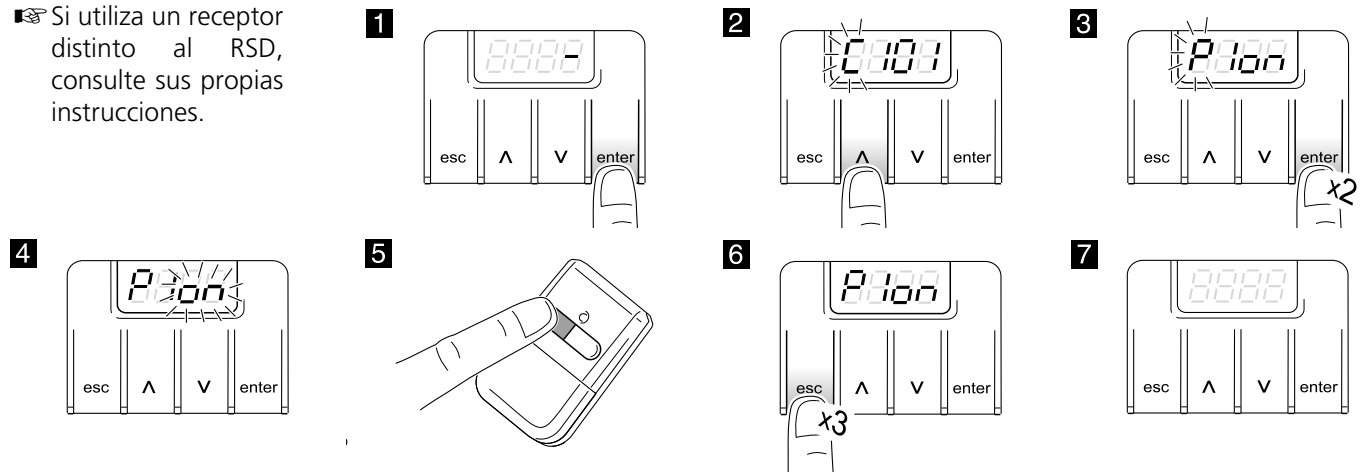

Para el correcto funcionamiento de la barrera, es imprescindible realizar la grabación del recorrido

Grabación del recorrido (P3)



Tabla completa de programación

D1	D2	Parámetro	D3	D4	Opción pre-determinada	Opciones o valores
C	1	Sentido de giro del motor	0	1	x	
			0	2		
	4					Deshabilitado
	5	Dispositivo de seguridad de cierre (fotocélula o banda)	0	0	x	Dispositivo no instalado
	1		0		Dispositivo sin testeo	
	1		1		Dispositivo con testeo	
P	1	Grabación código radio apertura total	0	n		
	2					Deshabilitado
	3	Grabación recorrido de la barrera	0	n		
F	1	Modo de funcionamiento	0	1		Automático
			0	2	x	Semi-automático
	2	Tiempo de espera en modo automático	0...5	0...9	15	59 = 59 seg.; 2.5 = 2 min. 50 seg., etc
	3					Deshabilitado
R	0	Lámpara destelleante	0	1	x	Sin preaviso
			0	2		Con preaviso
	1	Tiempo de luz de garaje	0...5	0...9	03	59 = 59 seg.; 2.5 = 2 min. 50 seg., etc
	2	Velocidad de la barrera	0	1...5	03	01: velocidad mínima; 05: velocidad máxima
	3	Velocidad en paro suave	0	1...5	02	01: velocidad mínima; 05: velocidad máxima
	4	Distancia paro suave	0	0...5	00	00: distancia mínima; 05: distancia máxima
	5					Deshabilitado
	6	Fuerza máxima	0...1	0...9	05	01: fuerza mínima; 10: fuerza máxima
	7	Paso por fotocélula de cierre durante tiempo de espera (sólo en modo automático)	0	1		Cierre inmediato
			0	2	x	Reinicia el tiempo de espera
			0	3		No tiene efecto
	8	Accionamiento del pulsador durante tiempo de espera (sólo en modo automático)	0	1		Cierre inmediato
			0	2	x	Reinicia el tiempo de espera
0			3		No tiene efecto	
9	Modo de apertura	0	1	x	Apertura según el modo seleccionado en las funciones principales (F)	
		0	2		Apertura comunitaria (durante la apertura, el cuadro de maniobra no obedece las ordenes de marcha)	
		0	3		Apertura paso a paso (si durante la apertura se acciona algún dispositivo de marcha, la barrera se detiene. Si se acciona de nuevo, la barrera se cierra)	
n	1	Maniobras realizadas	X	X		Indica los ciclos realizados, multiplicando la cifra indicada por una cantidad, por ejemplo: 68 indica 6.800 ciclos realizados 6.8 indica 68.000 ciclos realizados

AVERTISSEMENT

Ce guide rapide est un résumé du manuel d'installation complet. Ce manuel reprend les avertissements de sécurité et autres explications qui doivent être pris en compte. Vous pouvez télécharger le manuel d'installation dans la section " Téléchargement " du site Web d'Erreka : <http://www.erreka-automation.com>

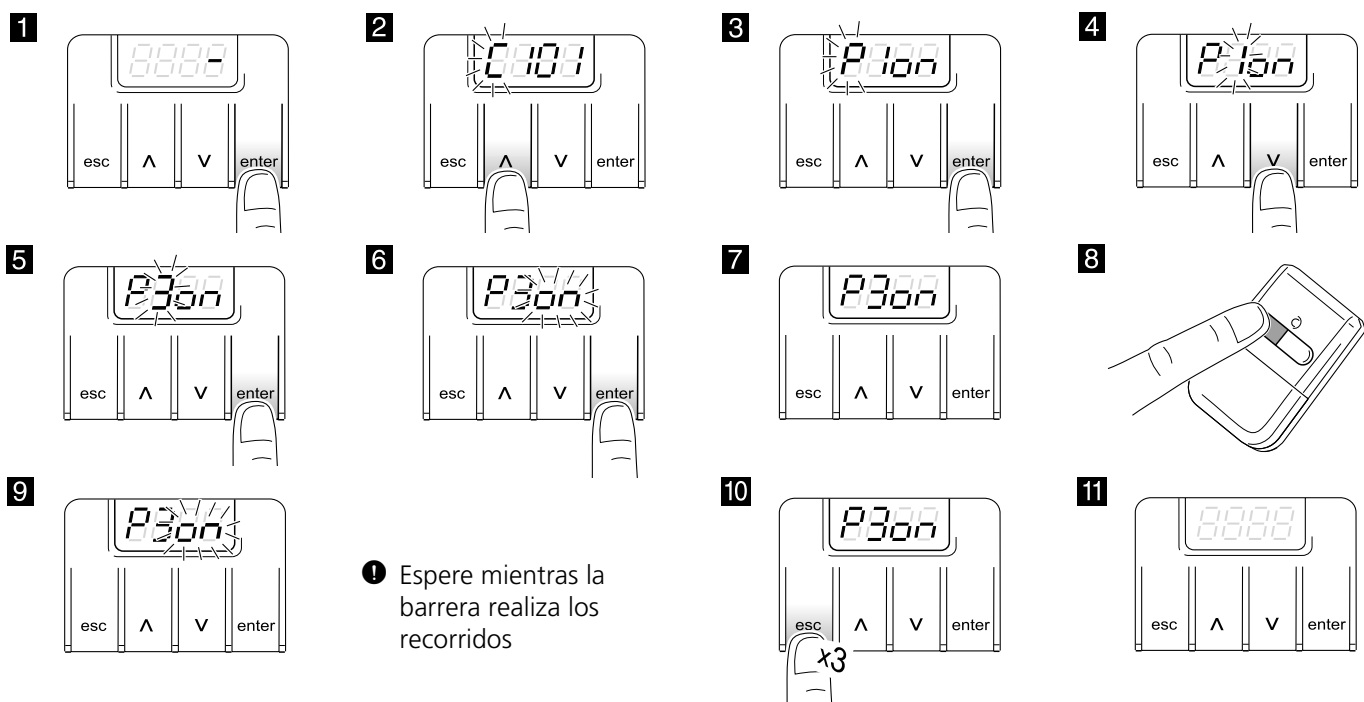
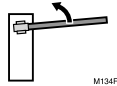
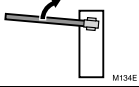
Éléments de l'installation complète

Câblage électrique

- A : Alimentation générale
- B : Feu clignotant
- C : Photocellules (Tx / Rx)
- D : Sélecteur à clé

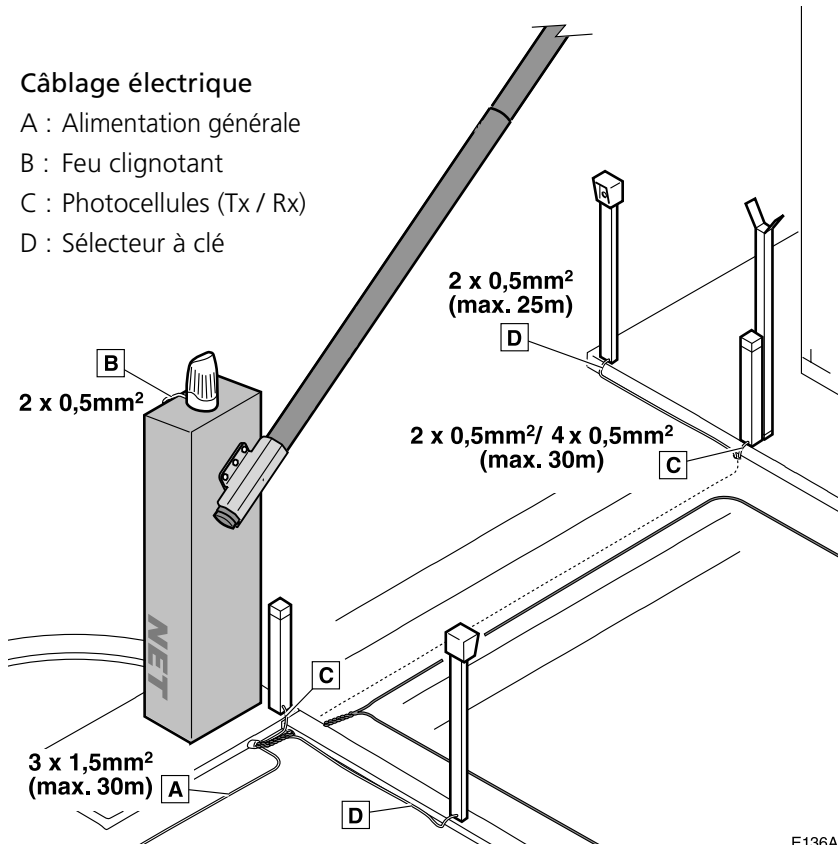

Déblocage

▲ Le déblocage doit être réalisé avec précaution. Si la barrière n'est pas équilibrée ou si le bras n'est pas monté, le ressort interne peut provoquer un déplacement violent.

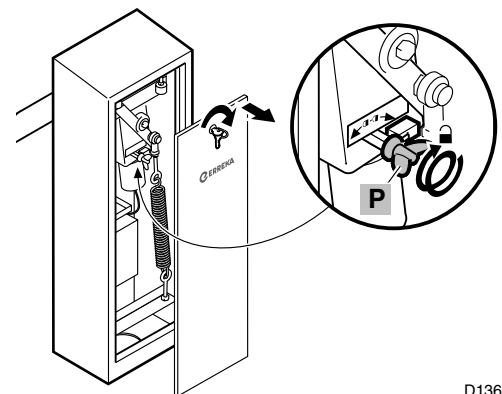

Déblocage (actionnement manuel) :
tournez l'écrou papillon (P) vers la droite jusqu'à la butée.

Blocage (actionnement motorisé) :
tournez l'écrou papillon (P) vers la gauche jusqu'à obtenir le blocage.

Montage du bras

La barrière est fournie pour un montage à droite. Si vous désirez la monter à gauche, avant d'installer le bras, effectuez le « Changement de côté » (voir la page suivante).

- 1 Bloquer l'actionneur et monter le premier tronçon.
- 2 Débloquer l'actionneur et baisser manuellement le bras.
- 3 Bloquer l'actionneur et monter le deuxième tronçon.

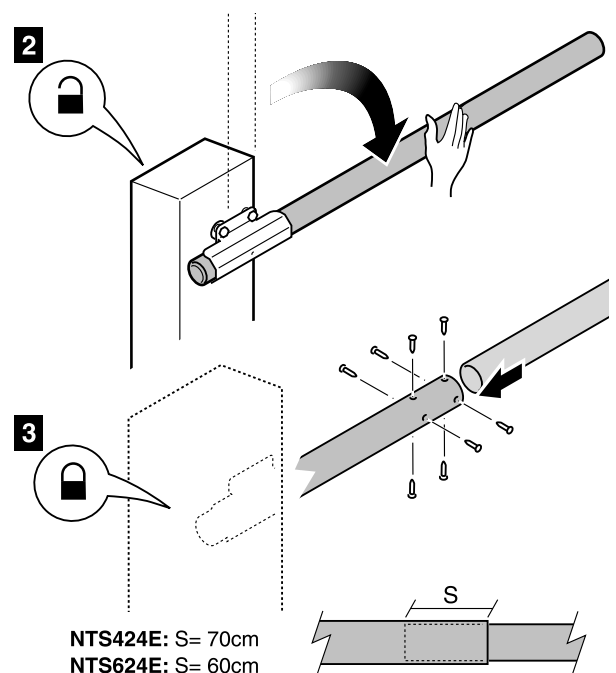
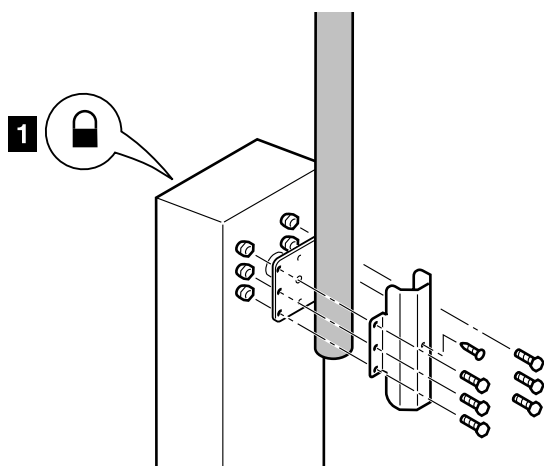

Changement de côté

Barrière droite

Barrière gauche

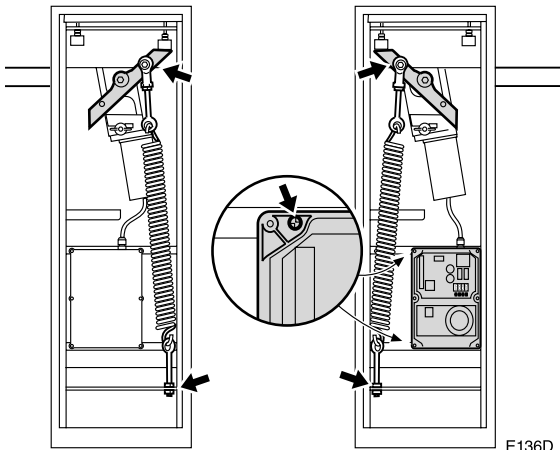

E136D

Équilibrage

POUR UN FONCTIONNEMENT CORRECT, IL EST INDISPENSABLE D'ÉQUILIBRER LA BARRIÈRE.

- Débloquez l'actionneur et tendez le ressort jusqu'à ce que la barrière soit équilibrée à 45°.

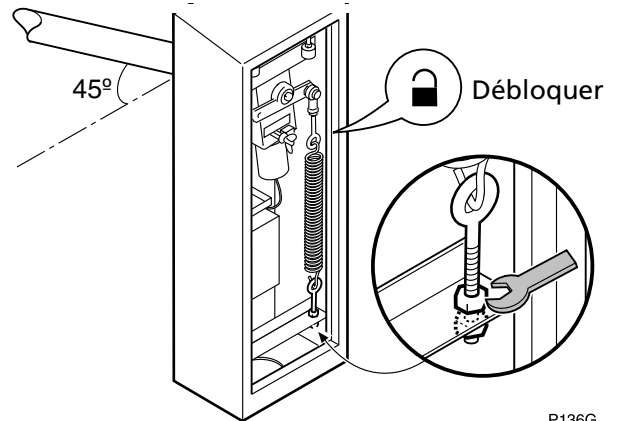

P136G

Connexion générale

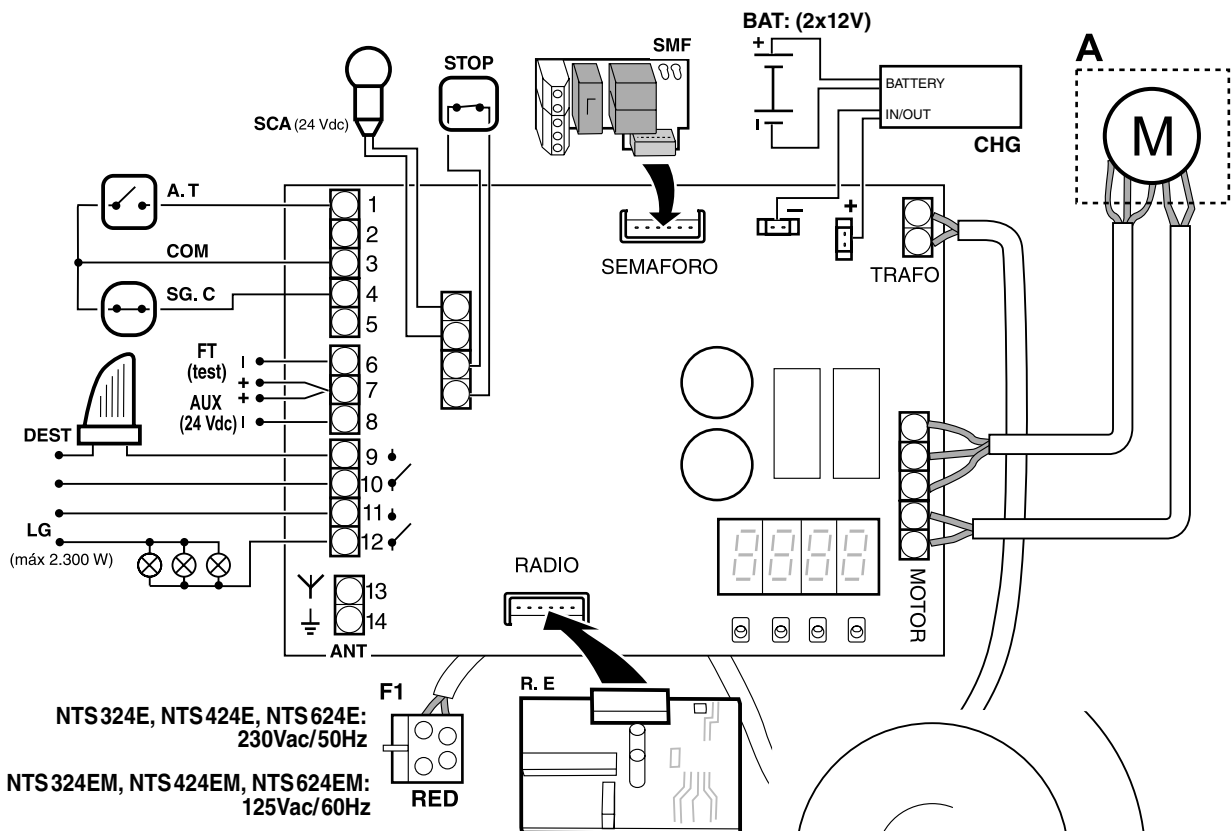

P136F

Indications du display

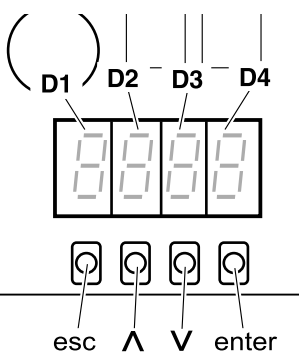

D1 et D2:

CL (fixe)	Barrière fermée
CL (clignotant)	Barrière en train de se fermer
OP (fixe)	Barrière ouverte
OP (clignotant)	Barrière en train de s'ouvrir
XX (compte à rebours)	Barrière en attente
STOP	Actionneur débloqué
PR (fixe)	Pause (manœuvre non terminée)
rs (fixe)	Barrière cherchant la position de fermeture

D3 et D4:

CS	Dispositif de sécurité en fermeture activé
E I	Encodeur moteur arrêté
F I	Limite de force dépassée
bA	Batterie en fonctionnement
Ft no	Photocellules défailtantes (test)

M136C

Changez le sens de rotation (⌈ I)

☞ Cette opération n'est nécessaire que si la barrière s'ouvre au lieu de se fermer pendant le reset (r5).

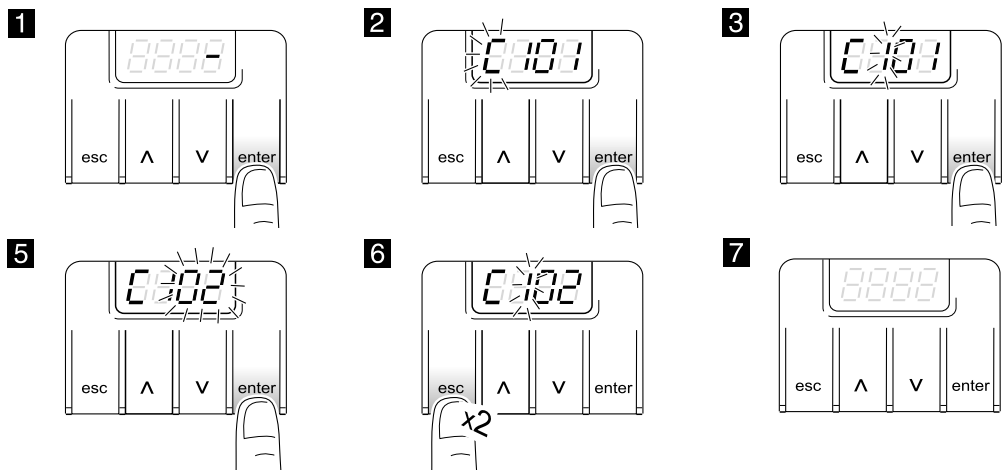

P58G

Enregistrement du code radio, P I (seulement avec récepteur RSD)

☞ Si vous utilisez un récepteur différent du RSD, consultez ses propres instructions.

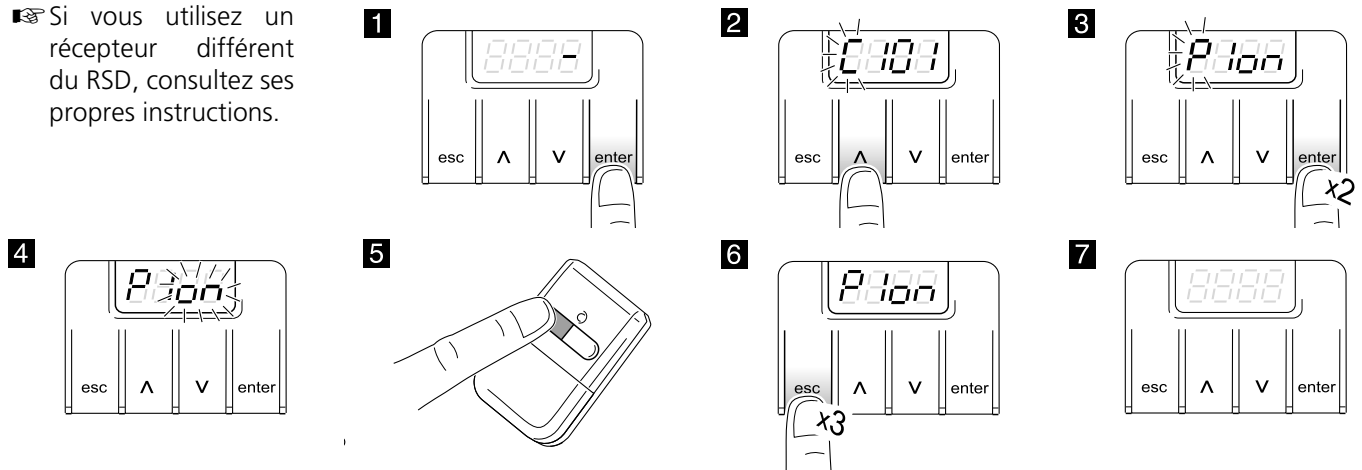

Pour le fonctionnement correct de la barrière, il faut impérativement enregistrer le parcours

Enregistrement du parcours (P3)



Tableau complet de programmation

D1	D2	Paramètre	D3	D4	Option prédéterminée	Options ou valeurs
C	1	Sens de rotation du moteur	0	1	x	
			0	2		
	4					Désactivé
	5	Dispositif de sécurité de fermeture (photocellule ou bande)	0	0	x	Dispositif non installé
1			0		Dispositif sans test	
1			1		Dispositif avec test	
P	1	Enregistrement code radio ouverture totale	0	0		
	2					Désactivé
	3	Enregistrement du parcours de la barrière	0	0		
F	1	Mode de fonctionnement	0	1		Automatique
			0	2	x	Semi-automatique
	2	Temps d'attente en mode automatique	0...5	0...9	15	59 = 59 sec. ; 2.5 = 2 min. 50 sec., etc
	3					Désactivé
R	0	Feu clignotant	0	1	x	Sans préavis
			0	2		Avec préavis
	1	Temps de lumière de garage	0...5	0...9	03	59 = 59 sec. ; 2.5 = 2 min. 50 sec., etc
	2	Vitesse de la barrière	0	1...5	03	0 1: vitesse minimale ; 05: vitesse maximale
	3	Vitesse en arrêt doux	0	1...5	02	0 1: vitesse minimale ; 05: vitesse maximale
	4	Distance arrêt doux	0	0...5	00	00: distance minimale ; 05: distance maximale
	5					Désactivé
	6	Force maximale	0...1	0...9	05	0 1: force minimale ; 10: force maximale
	7	Passage par photocellule de fermeture pendant le temps d'attente (seulement en mode automatique)	0	1		Fermeture immédiate
			0	2	x	Redémarre le temps d'attente
			0	3		Sans effet
	8	Actionnement du bouton-poussoir pendant le temps d'attente (seulement en mode automatique)	0	1		Fermeture immédiate
			0	2	x	Redémarre le temps d'attente
0			3		Sans effet	
9	Mode d'ouverture	0	1	x	Ouverture selon le mode sélectionné dans les fonctions principales (F)	
		0	2		Ouverture communautaire (pendant l'ouverture, l'armoire de commande n'obéit pas aux ordres de marche)	
		0	3		Ouverture pas à pas (si un dispositif de marche est actionné pendant l'ouverture, la porte s'arrête. S'il est à nouveau actionné, la porte se ferme)	
n	1	Manœuvres réalisées	X	X		Indique les cycles réalisés, en multipliant le chiffre indiqué par une quantité, par exemple : 68 indique 6800 cycles réalisés 6.8 indique 68000 cycles réalisés

IMPORTANT NOTE

This quick guide is a summary of the complete installation manual. The manual contains safety warnings and other explanations which must be taken into account. The installation manual can be downloaded by going to the "Downloads" section at the Erreka website:
<http://www.erreka-automation.com>

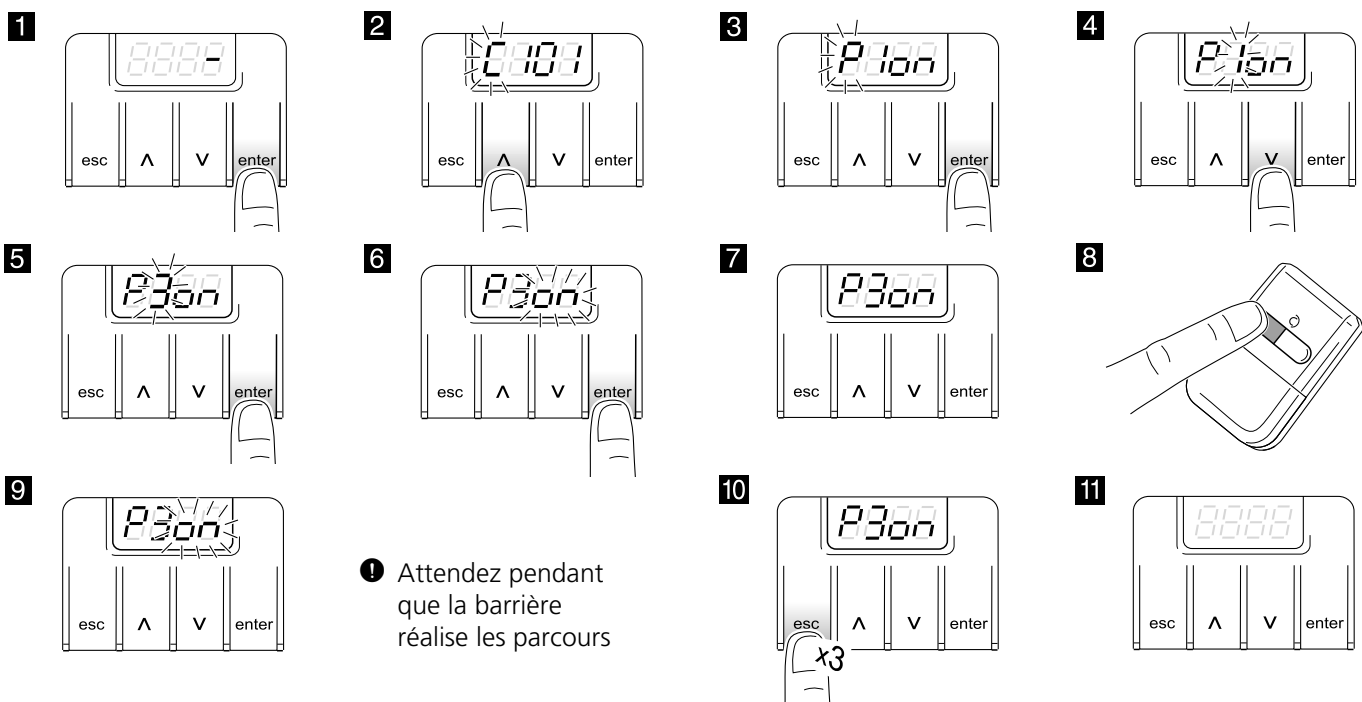
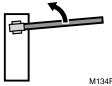
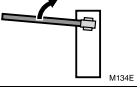
Elements of the complete installation

Electrical cabling

- A: Main power supply
- B: Flashing light
- C: Photocells (Tx / Rx)
- D: Key switch

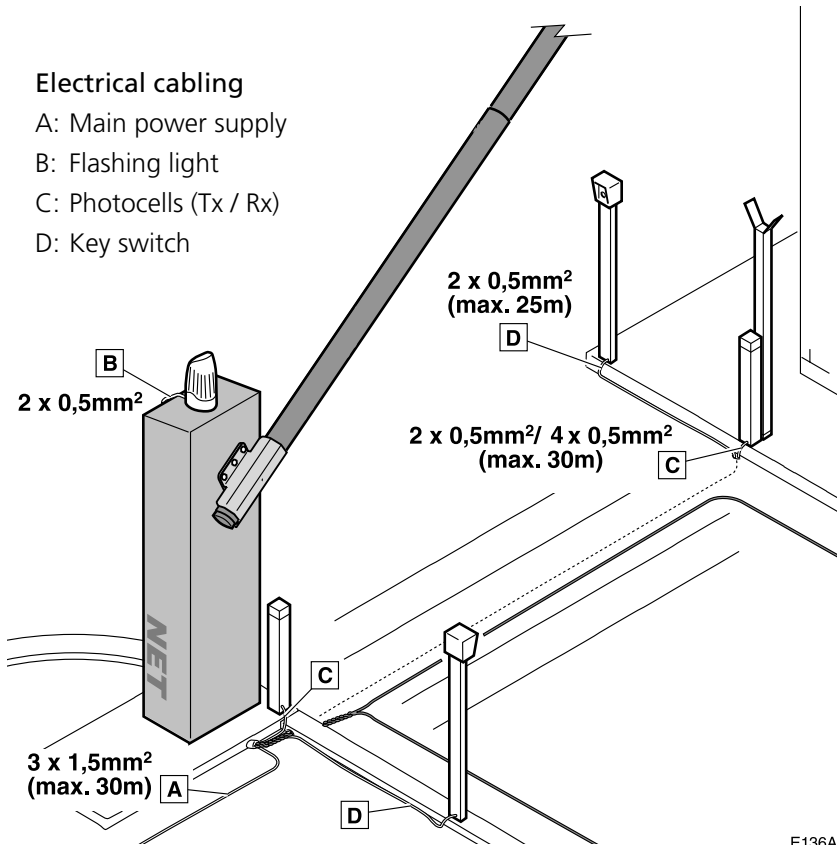

E136A

Unlocking

⚠ Unlocking should be carried out with caution. If the barrier is not balanced or the arm is not mounted, the internal spring may cause a violent movement.

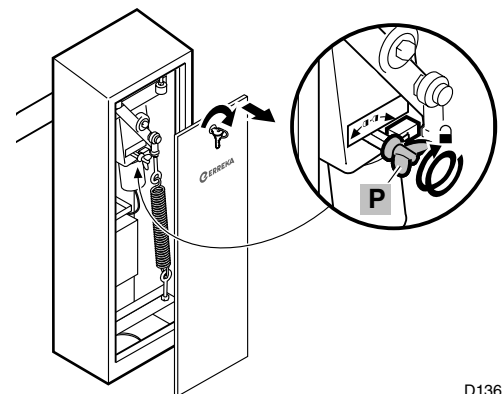

D136A

Unlocking (manual operation):

turn the wing knob (P) clockwise until it stops.

Lock (motorised operation):

turn the knob (P) anti-clockwise until it locks.

Arm assembly

✎ The barrier is supplied for assembly to the right. For assembly to the left, carry out the "Changing side" (see next page) before mounting the arm.

- 1 Lock the operator and mount the first section.
- 2 Unlock the operator and manually lower the arm.
- 3 Lock the operator and mount the second section.

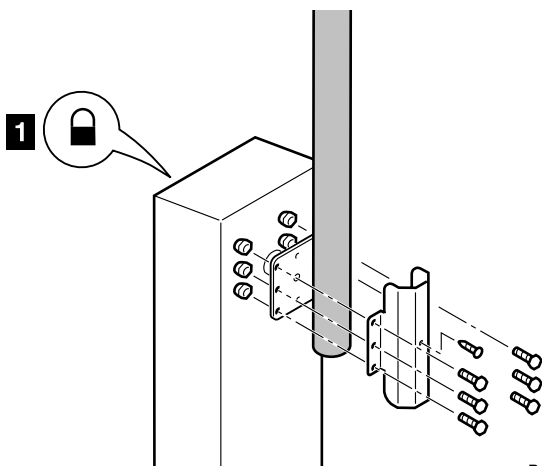

P136C1

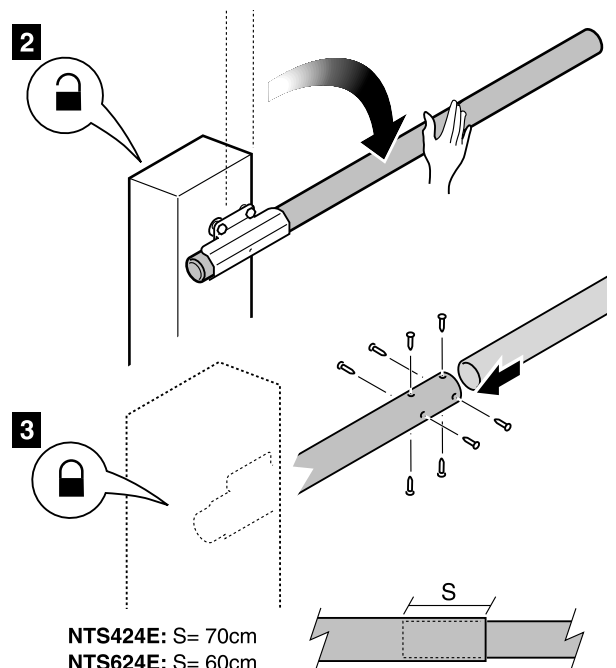

NTS424E: S= 70cm
 NTS624E: S= 60cm

P136C2

Changing side

Right barrier

Left barrier

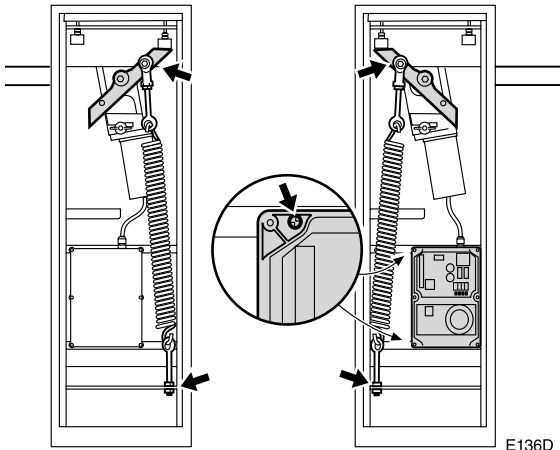

E136D

Balancing

⚠ THE BARRIER MUST BE BALANCED FOR PROPER OPERATION.

- Unlock the operator and tighten the spring until the barrier is balanced at 45°.

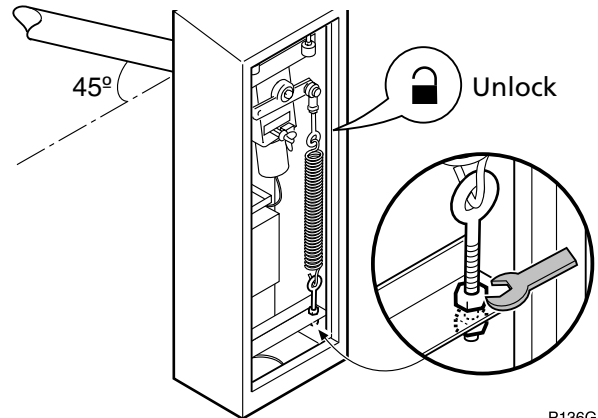

P136G

General connections

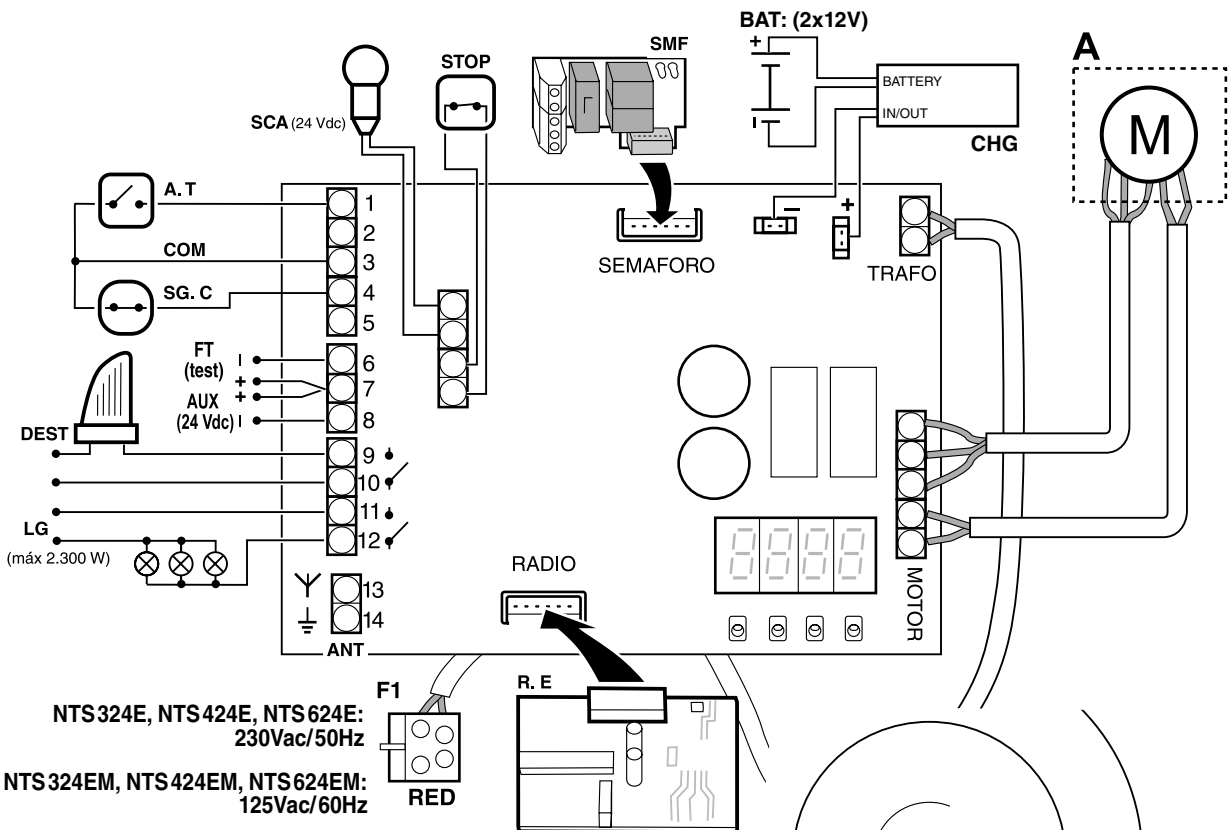

P136F

Display indications

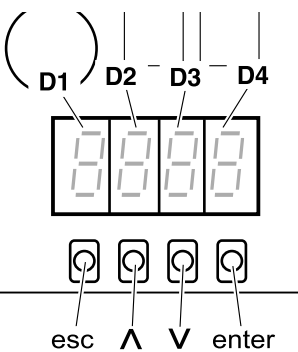

D1 and D2:

CL (static)	Barrier closed
CL (flashing)	Barrier closing
OP (static)	Barrier open
OP (flashing)	Barrier opening
XX (countdown)	Barrier on standby
STOP	Operator unlocked
PR (static)	Pause (operation not complete)
rs (static)	Barrier searching for close position

D3 and D4:

CS	Closing safety device activated
E I	Encoder motor halted
F I	Thrust limit exceeded
bA	Battery working
Ft no	Photocells defective (testing)

Change of turning direction (C I)

☞ This operation is only necessary if the barrier opens instead of closing when making a reset (r5).

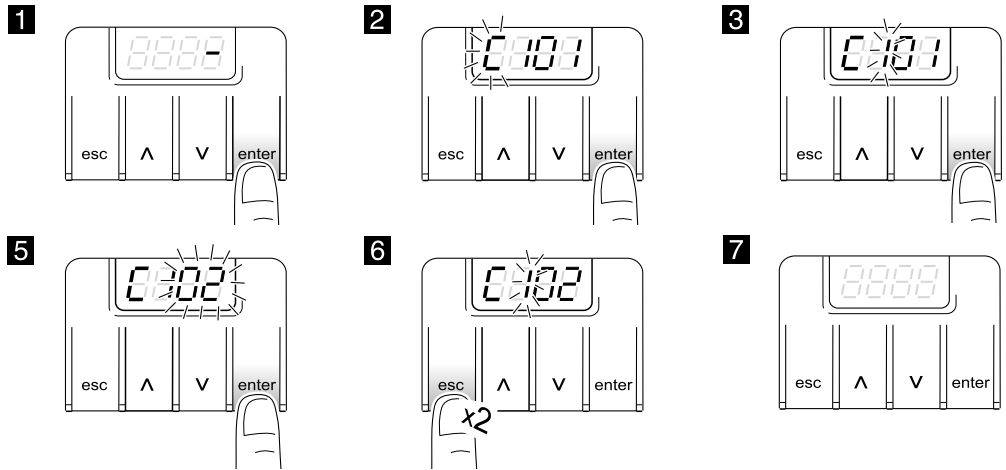

P58G

Radio code programming, P I (only with RSD receiver)

☞ If a receiver other than RSD is used, see the corresponding instructions.

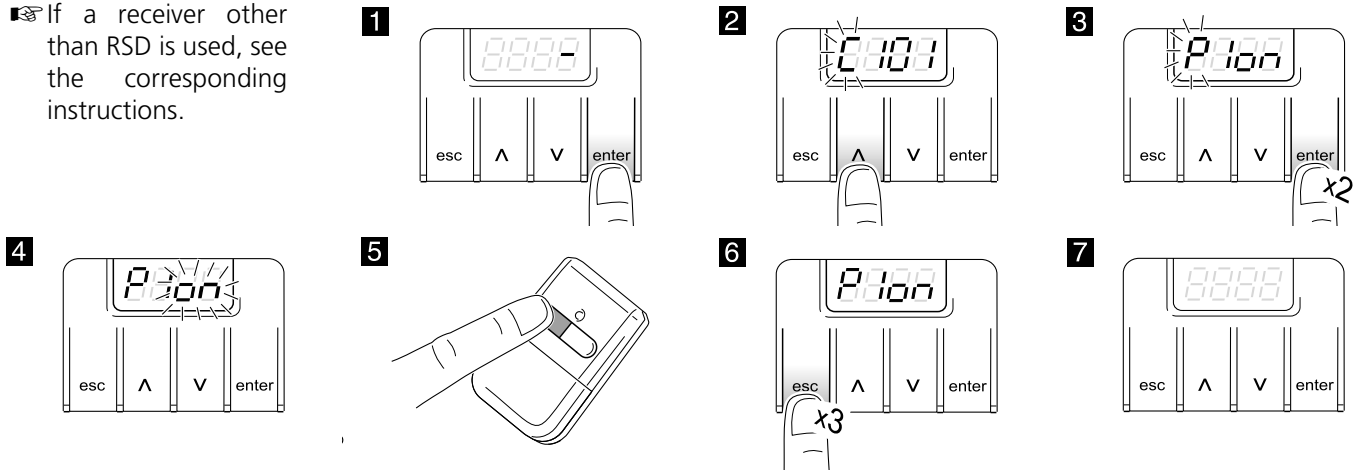

The travel of the barrier must be programmed for correct operation

Open/close programming (P3)

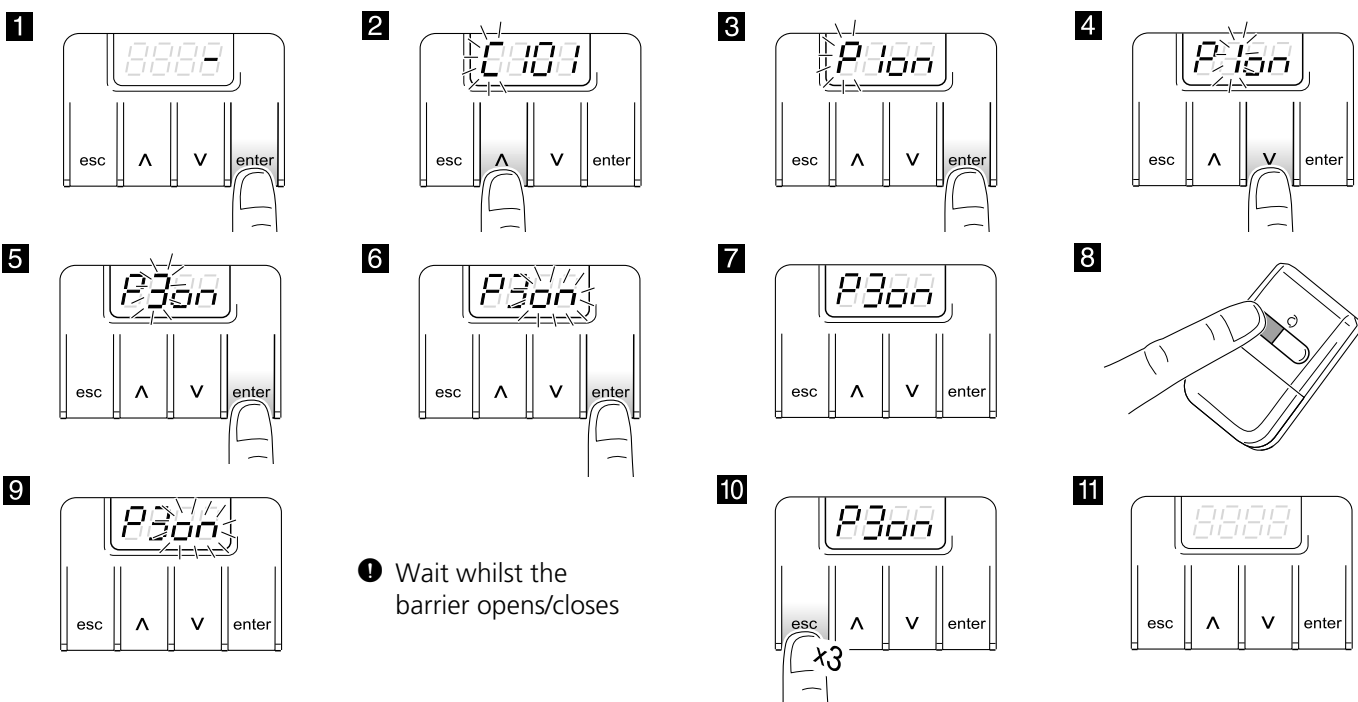

Complete programming chart

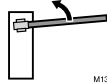
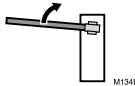
D1	D2	Parameter	D3	D4	Pre-determined option	Options or values
C	1	Motor turning direction	0	1	x	
			0	2		
	4					Disabled
	5	Closing safety device (photocell or strip)	0	0	x	Device not installed
			1	0		Device without testing
1			1		Device with testing	
P	1	Total opening radio code programming	0	n		
	2					Disabled
	3	Barrier open/close programming	0	n		
F	1	Functioning mode	0	1		Automatic
			0	2	x	Step-by-step
	2	Standby in automatic mode	0...5	0...9	15	59 = 59 sec.; 2.5 = 2 min. 50 sec., etc
	3				Disabled	
R	0	Flashing light	0	1	x	No warning
			0	2		With warning
	1	Garage light time	0...5	0...9	03	59 = 59 sec.; 2.5 = 2 min. 50 sec., etc
	2	Barrier speed	0	1...5	03	01: minimum speed; 05: maximum speed
	3	Slow down speed	0	1...5	02	01: minimum speed; 05: maximum speed
	4	Slowdown distance	0	0...5	00	00: minimum distance; 05: maximum distance
	5					Disabled
	6	Maximum thrust	0...1	0...9	05	01: minimum thrust; 10: maximum thrust
	7	Closing photocell used during standby (in automatic mode only)	0	1		Immediate close
			0	2	x	Restart standby time
			0	3		Has no effect
	8	Pushbutton operation during standby (in automatic mode only)	0	1		Immediate close
			0	2	x	Restart standby time
			0	3		Has no effect
	9	Opening mode	0	1	x	Opening in accordance with the mode selected in the main functions (F)
0			2		Collective opening (the control board does not obey the commands during opening)	
0			3		Step-by-step opening (the barrier halts if a key command is activated during opening. The barrier closes if activated again)	
n	1	Operations carried out	X	X		Indicates the cycles completed, multiplying the indicated figure by an amount, for example: 68 indicates 6,800 cycles completed 6.8 indicates 68,000 cycles completed

AVISO

Este guia rápido é um resumo do manual de instalação completo, que contém advertências de segurança e outras explicações que devem ser tidas em atenção. Pode fazer o download do manual de instalação na secção "Downloads" do site da Erreka: <http://www.erreka-automation.com>

Elementos da instalação completa

Cablagem eléctrica

- A: Alimentação geral
- B: Lâmpada brilhante
- C: Fotocélulas (Tx / Rx)
- D: Selector de chave

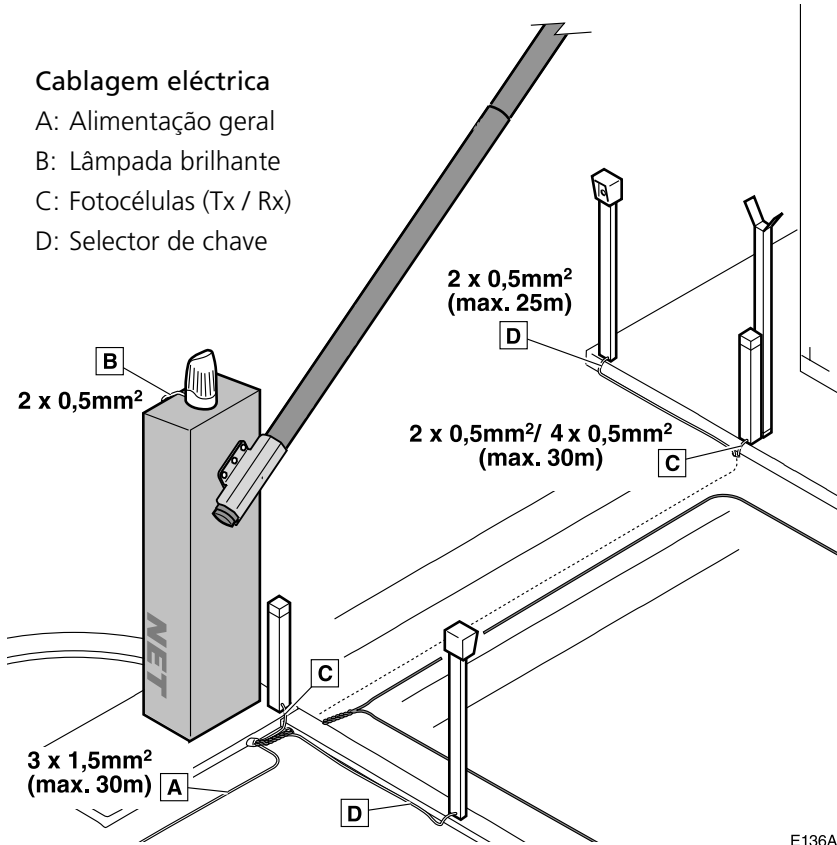

E136A

Desbloqueio

⚠ O desbloqueio deve ser realizado com precaução. Se a barreira não estiver equilibrada ou o braço não estiver montado, a mola interna pode originar um deslocamento violento.

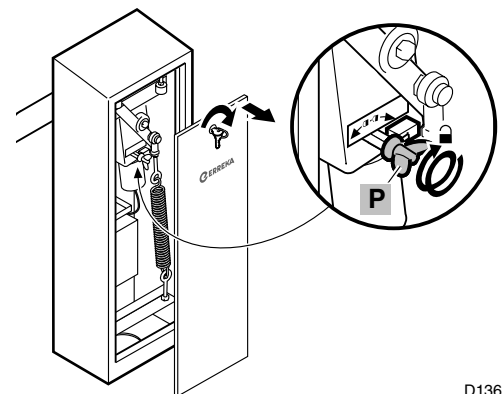

D136A

Desbloqueio (accionamento manual): gire a porca de orelhas (P) para a direita, até ao batente.

Bloqueio (accionamento motorizado): gire a porca de orelhas (P) para a esquerda, até obter o bloqueio.

Montagem do braço

✎ A barreira é fornecida para ser montada à direita. Se pretende montá-la à esquerda, antes de montar o braço efectue a "Mudança de lado" (ver página seguinte).

- 1 Bloquear o accionador e montar a primeira secção.
- 2 Desbloquear o accionador e baixar manualmente o braço.
- 3 Bloquear o accionador e montar a segunda secção.

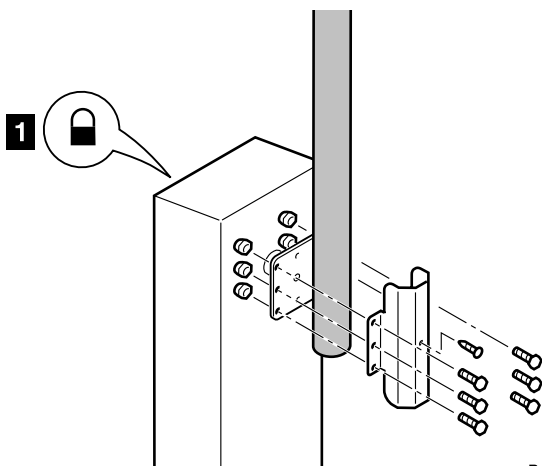

P136C1

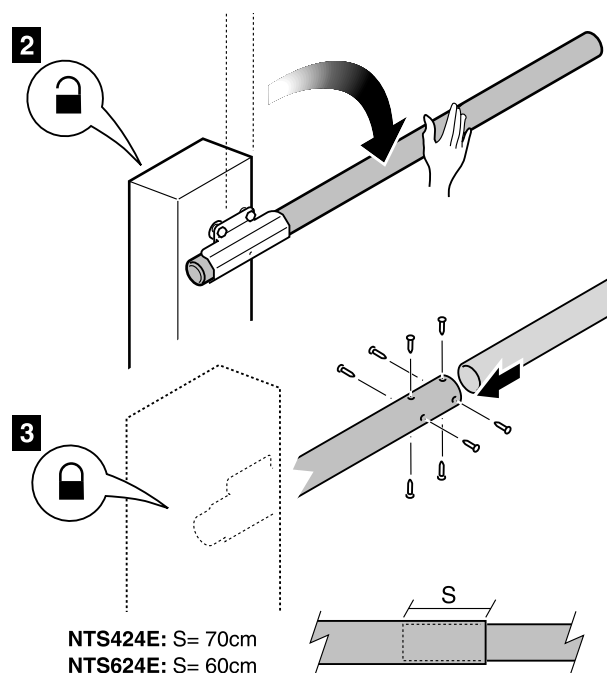

NTS424E: S= 70cm
NTS624E: S= 60cm

P136C2

Mudança de lado

Barreira da direita

Barreira da esquerda

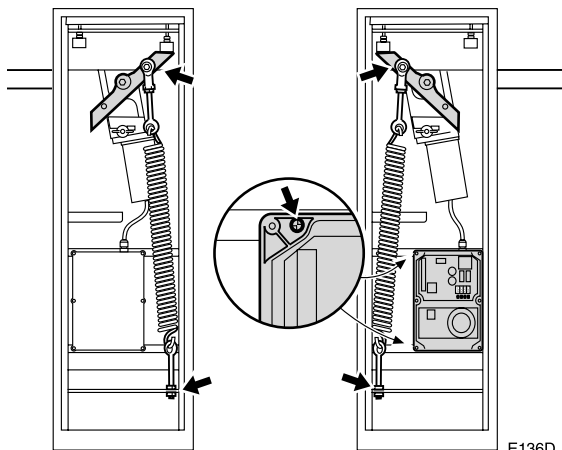

E136D

Equilibrado

✋ **PARA UM FUNCIONAMENTO CORRECTO É IMPRESCINDÍVEL EQUILIBRAR A BARREIRA.**

- Desbloqueie o accionador e estique a mola, até que a barreira fique equilibrada a 45°.

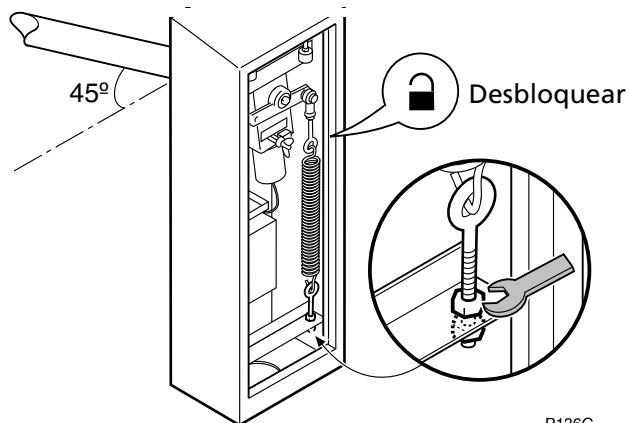

P136G

Ligação geral

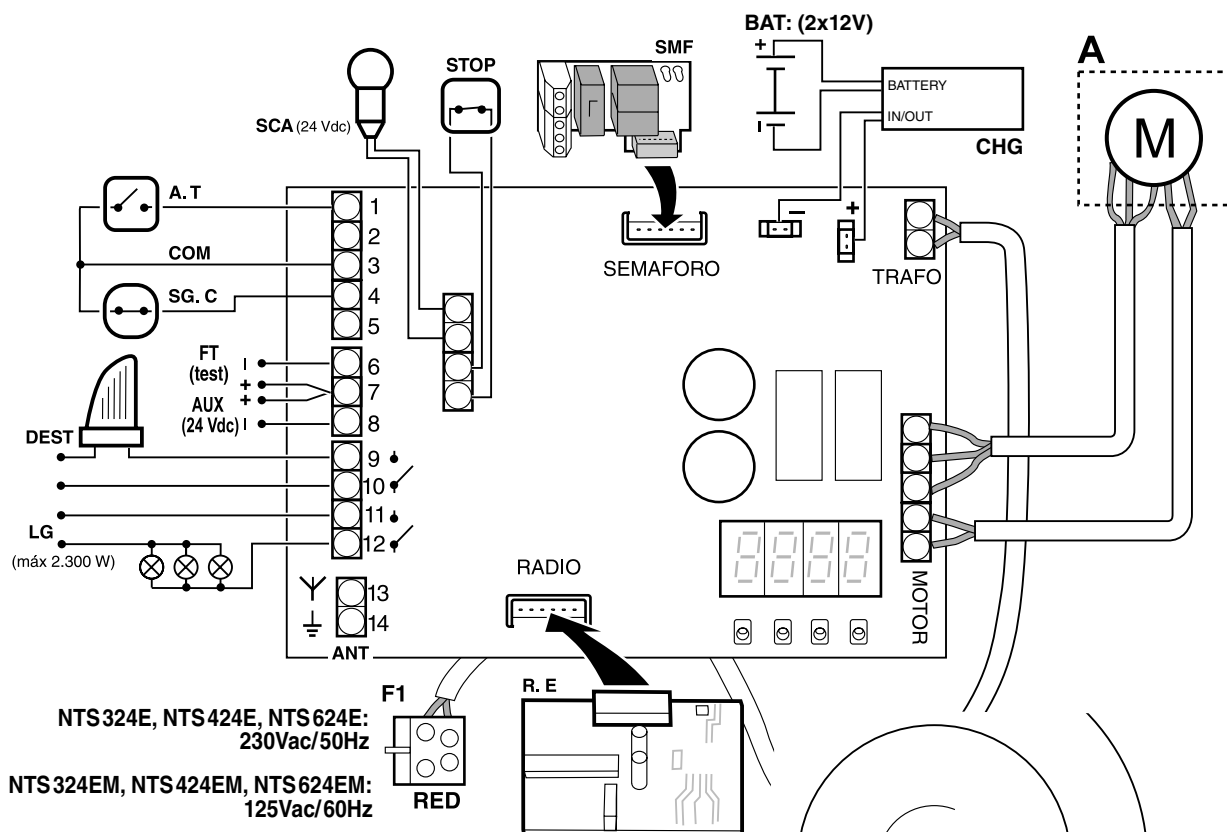

P136F

Indicações do visor

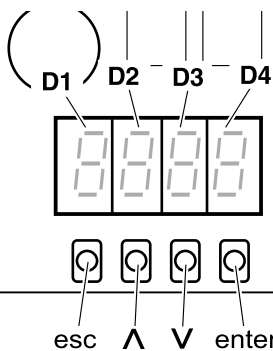

D1 e D2:

CL (fixo)	Barreira fechada
CL (a piscar)	Barreira a fechar-se
OP (fixo)	Barreira aberta
OP (a piscar)	Barreira a abrir-se
XX (impulso atrás)	Barreira em espera
StOP	Accionador desbloqueado
PR (fixo)	Pausa (manobra não concluída)
rS (fixo)	Barreira a procurar posição de fecho

D3 e D4:

CS	Dispositivo de segurança no fecho activado
E I	Encoder do motor parado
F I	Limite de força ultrapassado
bA	Bateria em funcionamento
Ft no	Fotocélulas defeituosas (testagem)

Mudança do sentido de rotação (C I)

Esta operação só é necessária se a barreira se abrir em vez de fechar, ao fazer reset (r5).

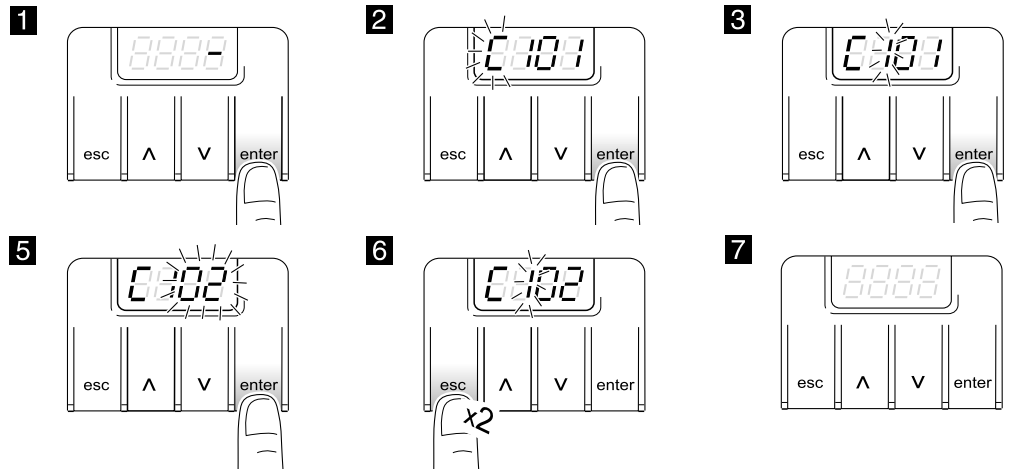

P58G

Gravação do código de rádio, P I (apenas com o receptor RSD)

Se utilizar um receptor diferente do RSD, consulte as respectivas instruções.

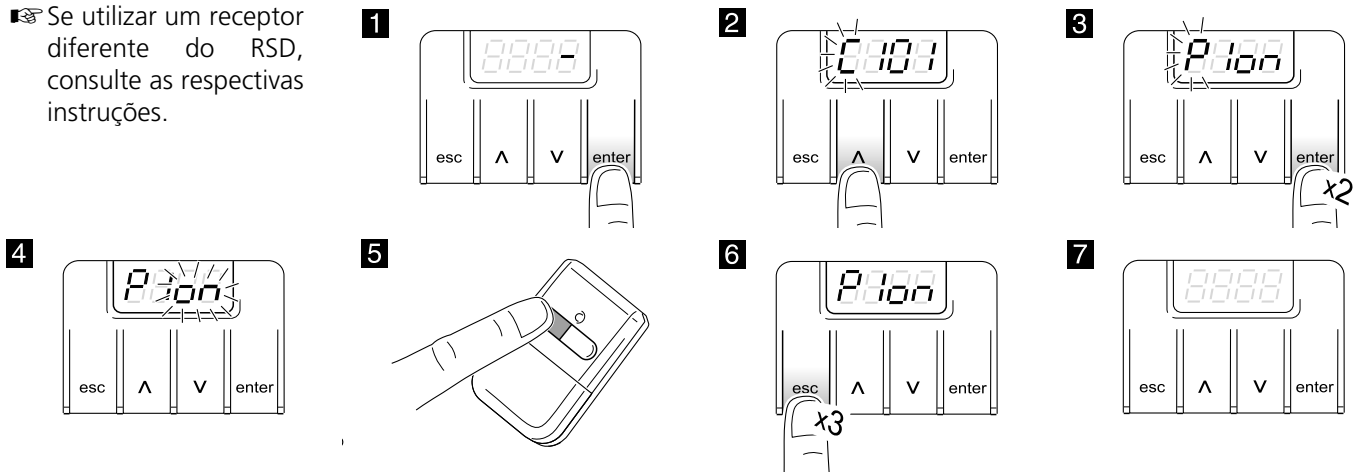

Para o funcionamento correcto da barreira é imprescindível efectuar a gravação do percurso

Gravação do percurso (P3)

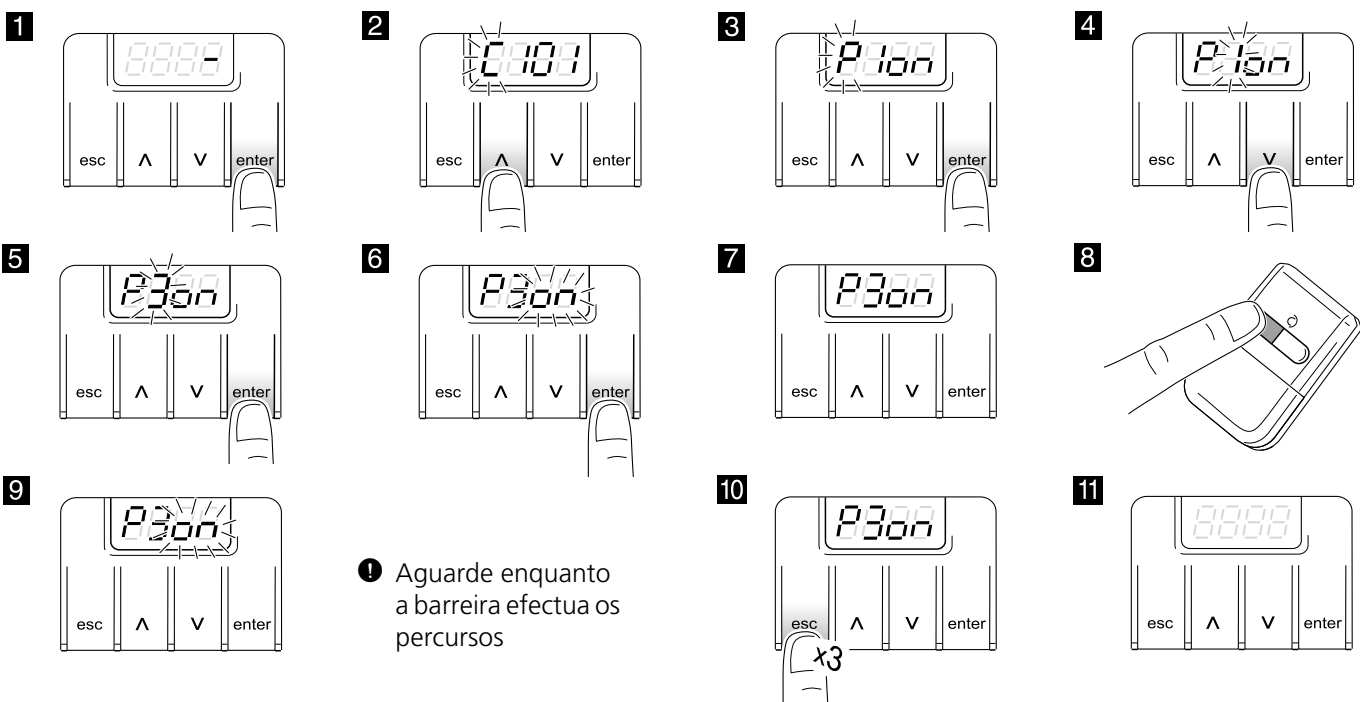

⚠ Aguarde enquanto a barreira efectua os percursos

Tabela completa de programação

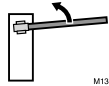
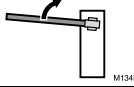
D1	D2	Parâmetro	D3	D4	Opção pré-determinada	Opções ou valores
C	1	Sentido de rotação do motor	0	1	x	
			0	2		
	4					Desactivado
	5	Dispositivo de segurança de fecho (fotocélula ou banda)	0	0	x	Dispositivo não instalado
1			0		Dispositivo sem testagem	
1			1		Dispositivo com testagem	
P	1	Gravação do código de rádio abertura total	o	n		
	2					Desactivado
	3	Gravação do percurso da barreira	o	n		
F	1	Modo de funcionamento	0	1		Automático
			0	2	x	Semi-automático
	2	Tempo de espera no modo automático	0...5	0...9	15	59 = 59 seg.; 2.5 = 2 min. 50 seg., etc
3					Desactivado	
R	0	Lâmpada brilhante	0	1	x	Sem pré-aviso
			0	2		Com pré-aviso
	1	Tempo de luz de garagem	0...5	0...9	03	59 = 59 seg.; 2.5 = 2 min. 50 seg., etc
	2	Velocidade da barreira	0	1...5	03	01: velocidade mínima; 05: velocidade máxima
	3	Velocidade na paragem suave	0	1...5	02	01: velocidade mínima; 05: velocidade máxima
	4	Distância de paragem suave	0	0...5	00	00: distância mínima; 05: distância máxima
	5					Desactivado
	6	Força máxima	0...1	0...9	05	01: força mínima; 10: força máxima
	7	Passo por fotocélula de fecho durante o tempo de espera (apenas no modo automático)	0	1		Fecho imediato
			0	2	x	Reinicia o tempo de espera
			0	3		Não tem efeito
	8	Accionamento do botão durante o tempo de espera (apenas no modo automático)	0	1		Fecho imediato
			0	2	x	Reinicia o tempo de espera
0			3		Não tem efeito	
9	Modo de abertura	0	1	x	Abertura segundo o modo seleccionado nas funções principais (F)	
		0	2		Abertura comunitária (durante a abertura, o painel de comando não obedece às ordens de marcha)	
		0	3		Abertura passo a passo (se durante a abertura se accionar algum dispositivo de marcha, a barreira parará. Se for accionado novamente, a barreira fechar-se-á)	
n	1	Manobras realizadas	X	X		Indica os ciclos realizados, multiplicando o número indicado por uma quantidade, por exemplo: 68 indica 6800 ciclos realizados 6.8 indica 68 000 ciclos realizados

HINWEIS

Dieser Kurzführer ist eine Zusammenfassung der kompletten Montageanleitung. Diese Anleitung enthält Sicherheitshinweise und andere Erläuterungen, die beachtet werden müssen. Die Montageanleitung können Sie auf der Erreka-Website unter "Downloads" herunterladen:
<http://www.erreka-automation.com>

Elemente der kompletten Anlage

Stromkabel

- A: Hauptstromversorgung
- B: Blinklampe
- C: Lichtschranke (Tx / Rx)
- D: Schlüsseltaster

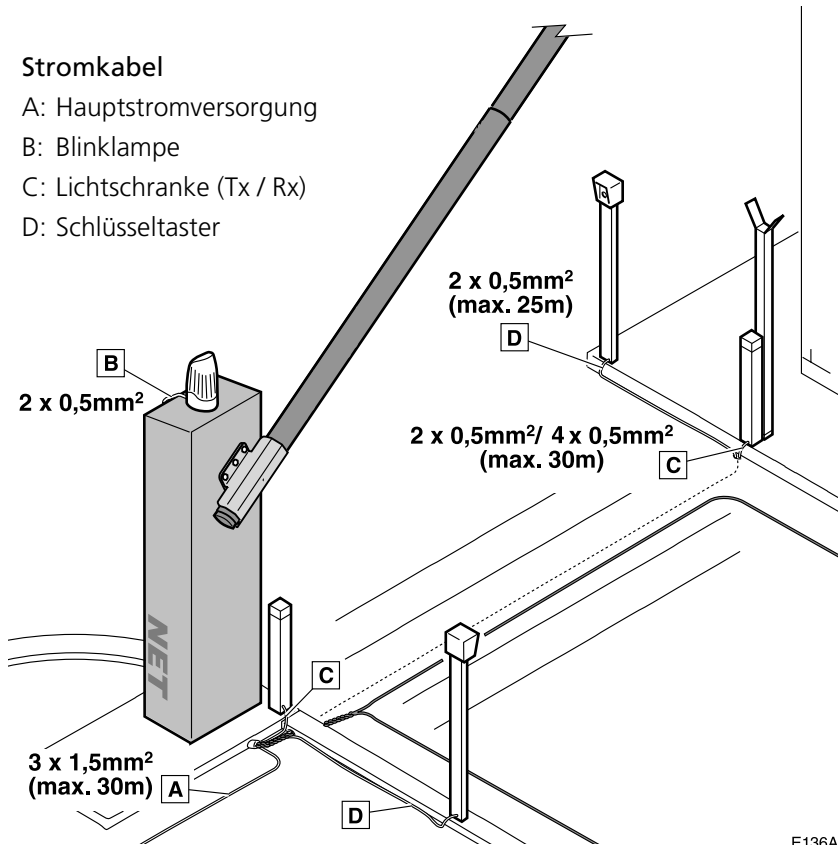

E136A

Entriegelung

⚠ Die Entriegelung muss vorsichtig erfolgen. Ist die Schranke nicht ausgeglichen oder der Balken nicht montiert, kann die interne Feder eine plötzliche Bewegung verursachen.

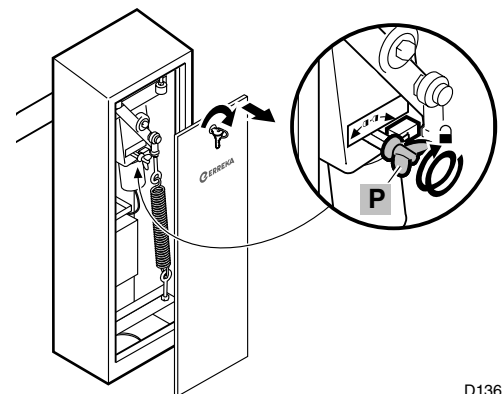

D136A

Entriegelung (manuelle Betätigung):
 Flügelschraube (P) bis zum Anschlag nach rechts drehen.

Verriegelung (motorischer Antrieb):
 Flügelschraube (P) bis zum Anschlag nach links drehen, bis die Blockierung erfolgt ist.

Montage des Balkens

☞ Die Schranke wird für die Montage auf der rechten Seite geliefert. Soll sie links montiert werden, muss vor der Schrankenmontage der „Seitenwechsel“ (siehe folgende Seite) durchgeführt werden.

- 1 Antrieb sperren und den ersten Abschnitt montieren.
- 2 Antrieb freigeben und die Schranke manuell absenken.
- 3 Antrieb sperren und den zweiten Abschnitt montieren.

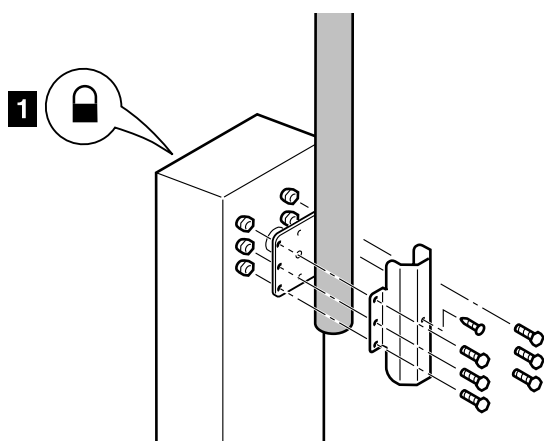

P136C1

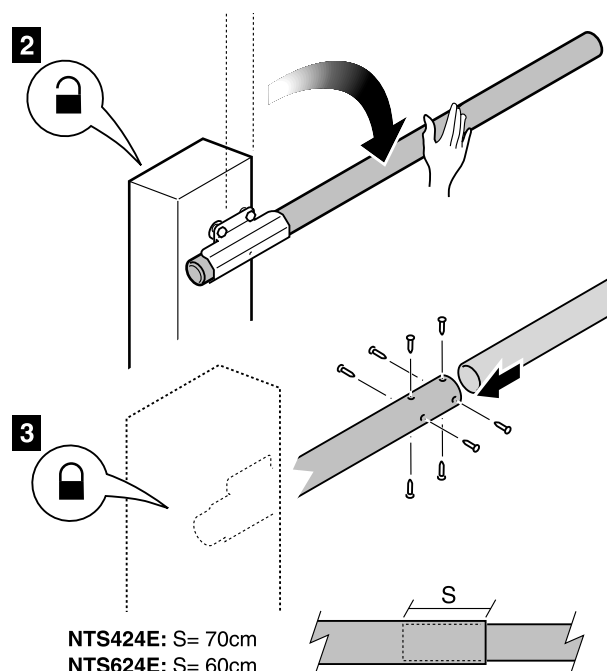

NTS424E: S= 70cm
 NTS624E: S= 60cm

P136C2

Seitenwechsel

Schranke rechts

Schranke links

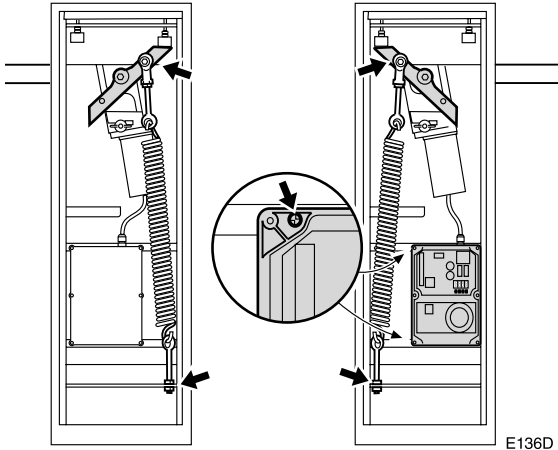

E136D

Ausgleich

FÜR EINEN EINWANDFREIEN BETRIEB MUSS DIE SCHRANKE UNBEDINGT AUSGEGlichen WERDEN.

- Geben Sie den Antrieb frei und spannen Sie die Feder, bis die Schranke bei 45° ausgeglichen ist.

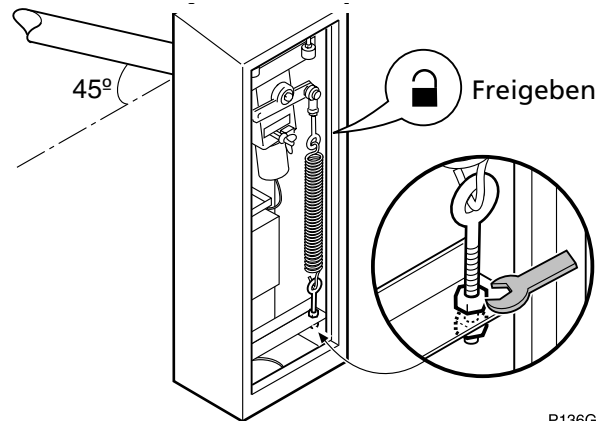

P136G

Allgemeine Anschlüsse

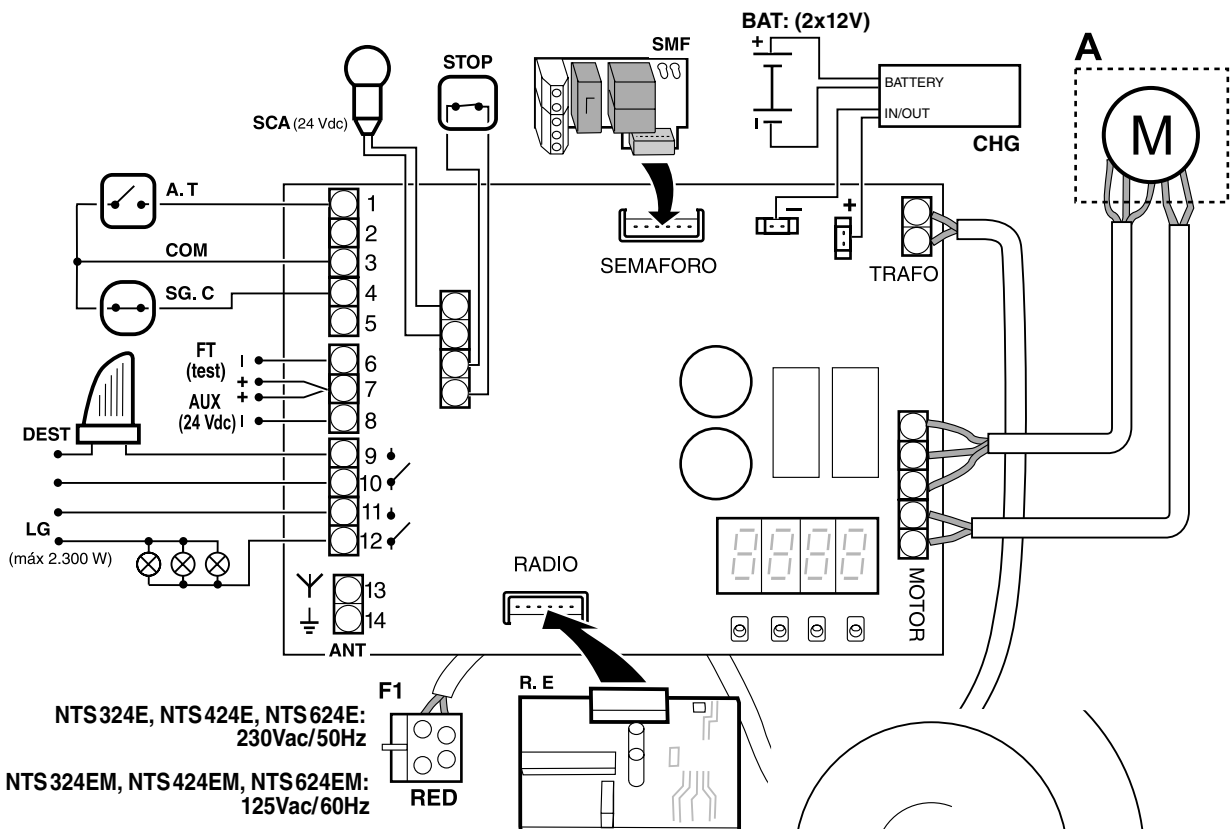

P136F

Displayanzeigen

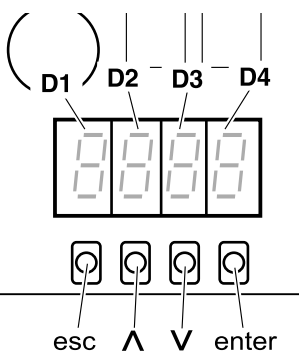

D1 und D2:

CL (kontinuierlich)	Schranke geschlossen
CL (blinkend)	Schranke schließt sich
OP (kontinuierlich)	Schranke geöffnet
OP (blinkend)	Schranke öffnet sich
XX (Countdown)	Schranke wartet
STOP	Antrieb freigegeben
PR (kontinuierlich)	Pause (Vorgang nicht beendet)
rs (kontinuierlich)	Schranke sucht Schließposition

D3 und D4:

CS	Sicherheitsvorrichtung Schließen aktiviert
E I	Motorencoder gestoppt
F I	Kraftgrenze überschritten
bR	Batterie in Betrieb
Ft no	Lichtschranke defekt (Test)

Wechsel der Drehrichtung (L I)

➔ Dieser Vorgang ist nur erforderlich, wenn sich die Schranke beim Reset (-5) öffnet, anstatt sich zu schließen.

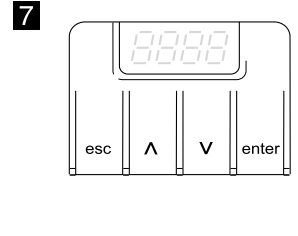
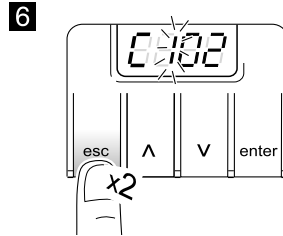
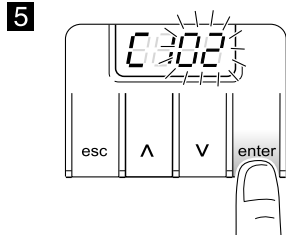
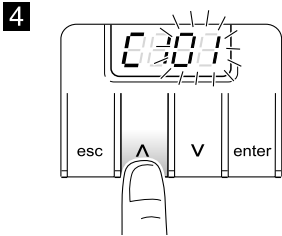
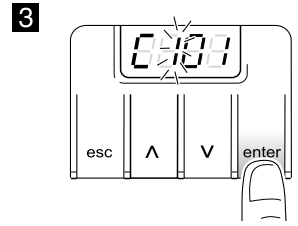
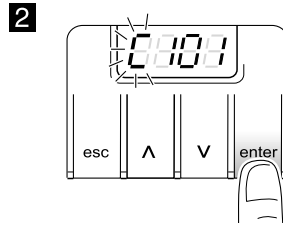
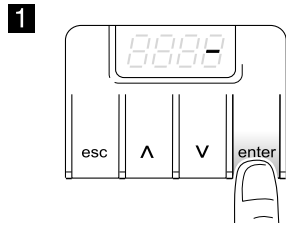

P58G

Speichern des Funkcodes, P I (nur mit Empfänger RSD)

➔ Wird ein anderer Empfänger als der RSD verwendet, in dessen Anleitung nachlesen.

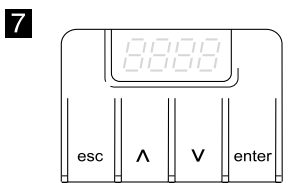
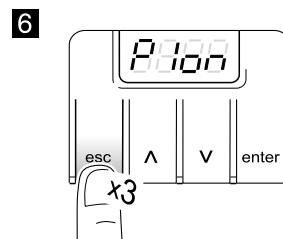
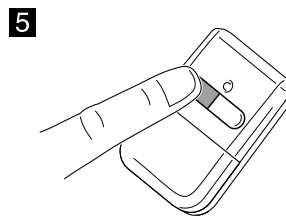
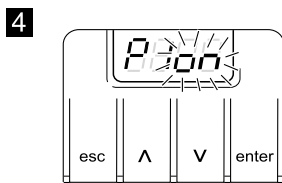
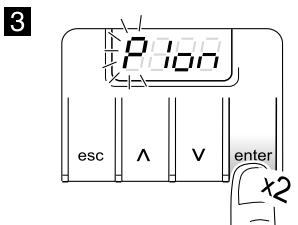
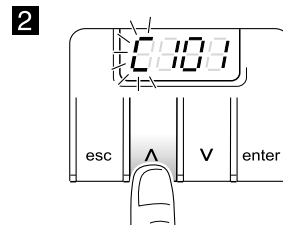
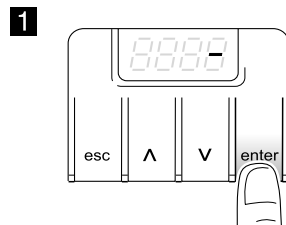

Für einen einwandfreien Betrieb der Schranke muss der Verfahrensweg gespeichert werden

Speichern des Verfahrenswegs (P3)

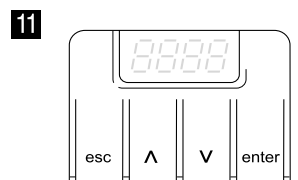
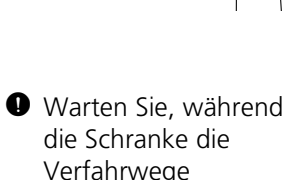
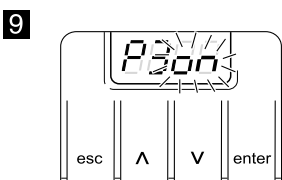
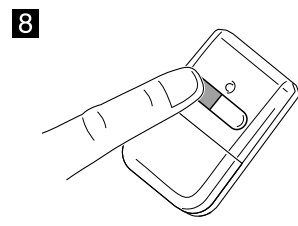
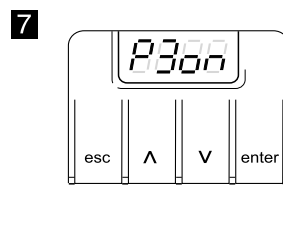
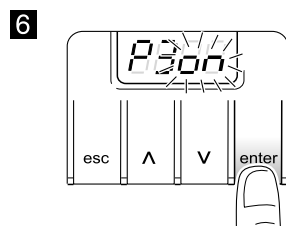
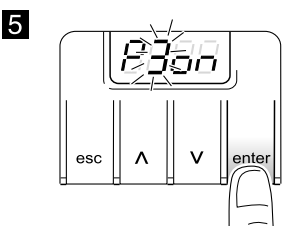
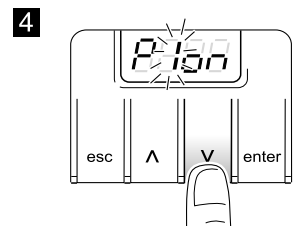
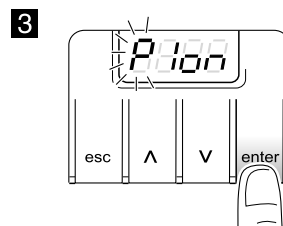
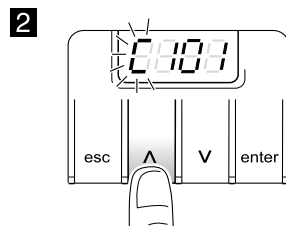
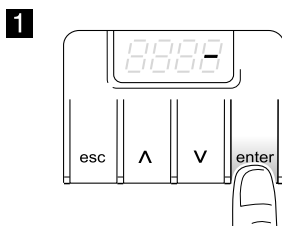

ⓘ Warten Sie, während die Schranke die Verfahrensweg durchführt

Komplette Programmiertabelle

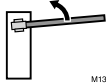
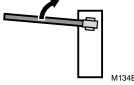
D1	D2	Parameter	D3	D4	Voreingestellte Option	Optionen oder Werte
C	1	Motordrehrichtung	0	1	x	
			0	2		
	4					Deaktiviert
	5	Sicherheitsvorrichtung Schließen (Lichtschranke oder Kontakteleiste)	0	0	x	Vorrichtung nicht installiert
			1	0		Vorrichtung ohne Testfunktion
1			1		Vorrichtung mit Testfunktion	
P	1	Speichern Funkcode Gesamtöffnung	o	n		
	2					Deaktiviert
	3	Speichern Verfahrenweg der Schranke	o	n		
F	1	Betriebsart	0	1		Automatik
			0	2	x	Halbautomatik
	2	Pausenzeit im Automatikbetrieb	0...5.	0...9	15	59 = 59 Sek.; 2.5 = 2 Min. 50 Sek., etc.
	3					Deaktiviert
R	0	Blinklampe	0	1	x	Ohne Vorblinken
			0	2		Mit Vorblinken
	1	Einschaltdauer Garagenlicht	0...5.	0...9	03	59 = 59 Sek.; 2.5 = 2 Min. 50 Sek., etc.
	2	Geschwindigkeit Schranke	0	1...5	03	01: Mindestgeschwindigkeit; 05: Höchstgeschwindigkeit
	3	Soft-Stopp-Geschwindigkeit	0	1...5	02	01: Mindestgeschwindigkeit; 05: Höchstgeschwindigkeit
	4	Soft-Stopp-Abstand	0	0...5	00	00: Mindestabstand; 05: Höchstabstand
	5					Deaktiviert
	6	Maximalkraft	0...1	0...9	05	01: Mindestkraft; 10: Maximalkraft
	7	Durchqueren der Lichtschranke Schließen während der Pausenzeit (nur im Automatikbetrieb)	0	1		Sofortiges Schließen
			0	2	x	Neustart der Pausenzeit
			0	3		Keine Auswirkung
	8	Betätigen des Drucktasters während der Pausenzeit (nur im Automatikbetrieb)	0	1		Sofortiges Schließen
			0	2	x	Neustart der Pausenzeit
			0	3		Keine Auswirkung
	9	Öffnungsmodus	0	1	x	Öffnung gemäß gewählter Betriebsart bei den Hauptfunktionen (F)
0			2		Sammelbetrieb beim Öffnen (während des Öffnenvorgangs reagiert die Steuerung nicht auf die Betriebsbefehle)	
0			3		Schrittbetrieb beim Öffnen (wird während des Öffnungsvorgangs ein Befehlsgerät betätigt, hält die Schranke an. Bei erneuter Betätigung schließt sich die Schranke)	
n	1	Durchgeführte Vorgänge	X	X		Zeigt die durchgeführten Zyklen an, wobei die angezeigte Ziffer mit einer Menge multipliziert wird, zum Beispiel: 68 zeigt 6.800 durchgeführte Zyklen an 6.8 zeigt 68.000 durchgeführte Zyklen an

UPOZORNĚNÍ

Tento stručný průvodce je shrnutím celého instalačního manuálu. Manuál obsahuje bezpečnostní upozornění a další vysvětlení, která je třeba brát v úvahu. Návod k instalaci si můžete stáhnout v části "Ke stažení" na webových stránkách Erreka: <http://www.erreka-automation.com>

Prvky instalace

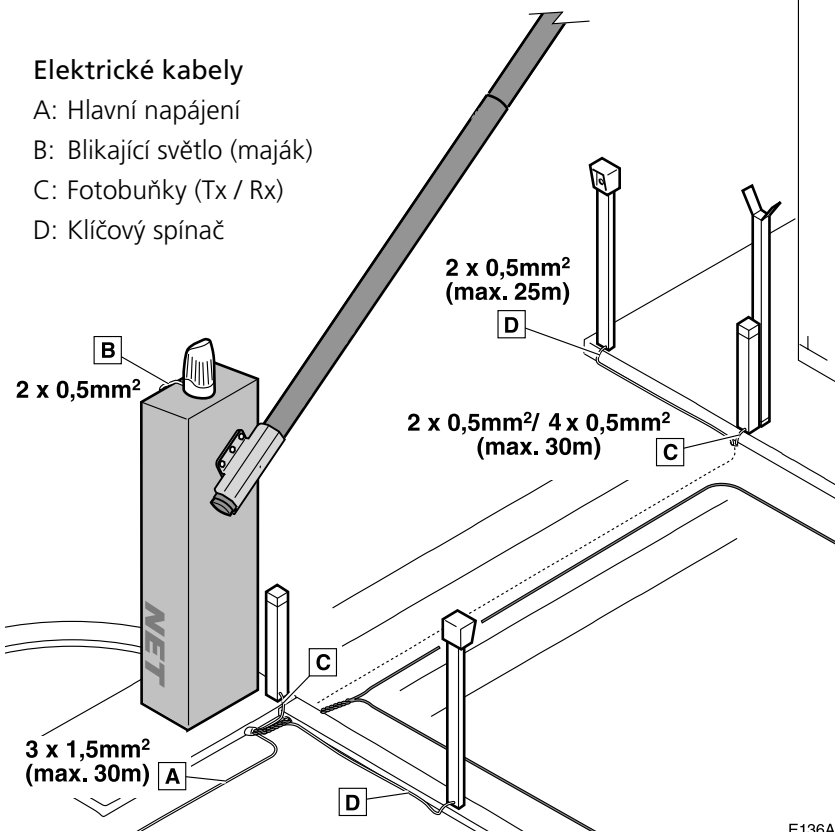

Odblokování

▲ Odblokování nutno provádět při zvýšené pozornosti. Není-li závora vyvážena a připevněno její rameno, vnitřní pružina může vyvolat prudký pohyb.

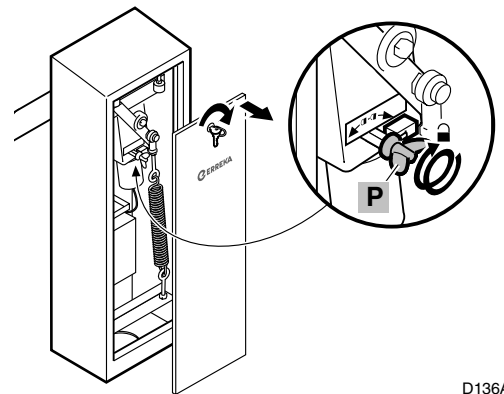

Odblokování (pro manuální aktivaci):
Otočte motýlkem (P) nadoraz, směrem doprava.

Zablokování (pro aktivaci pomocí motoru):
Otočte motýlkem (P) nadoraz, směrem doleva.

Montáž ramena

☞ Dodávaná závora je určena k montáži směrem doprava. Máte-li v úmyslu instalovat závora směrem doleva, bude nutno, před samotnou montáží ramena, provést tzv. "Změnu polohy" (vizte následující stránku).

- 1 Zablokujte aktivátor a přejděte k montáži první části ramena.
- 2 Aktivátor odblokujte a ručně stáhněte rameno dolů.
- 3 Potom aktivátor opět zablokujte a připevněte část následující.

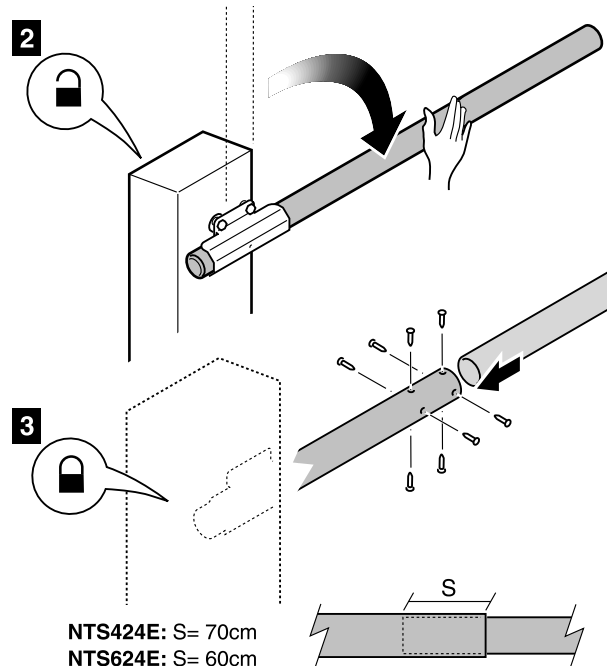
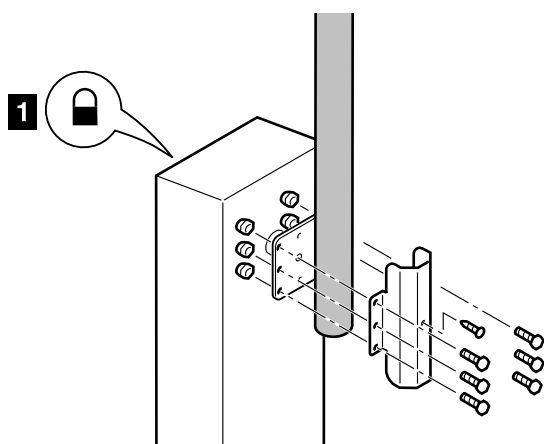

Změna polohy

Závora vpravo

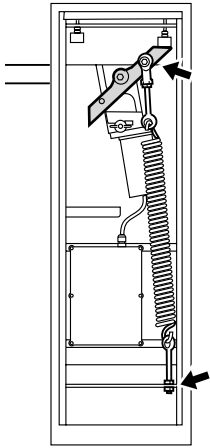

Závora vlevo

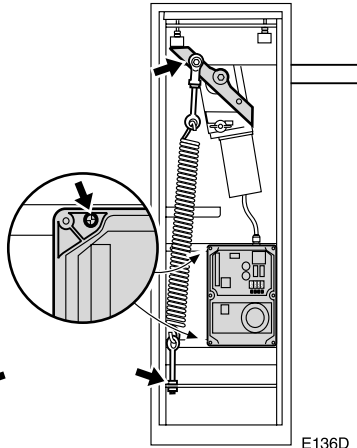

E136D

Vyvažování

➡ **PRO SPRÁVNÝ PROVOZ JE NEZBYTNÉ ZÁVORU VYVÁŽIT.**

- Odblokujte aktivátor a napněte pružinu tak, aby závora zůstala vyvážená do polohy 45°.

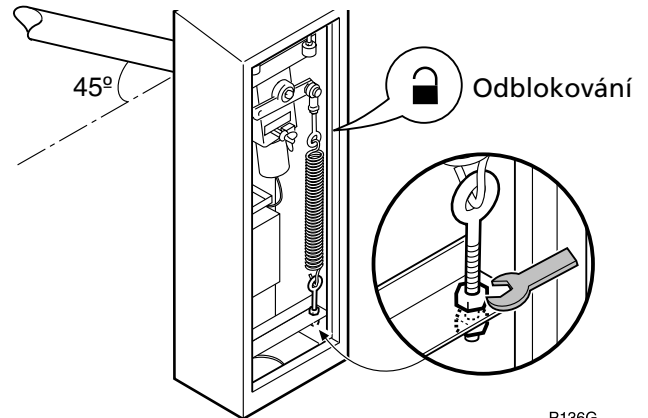

P136G

Hlavní připojení

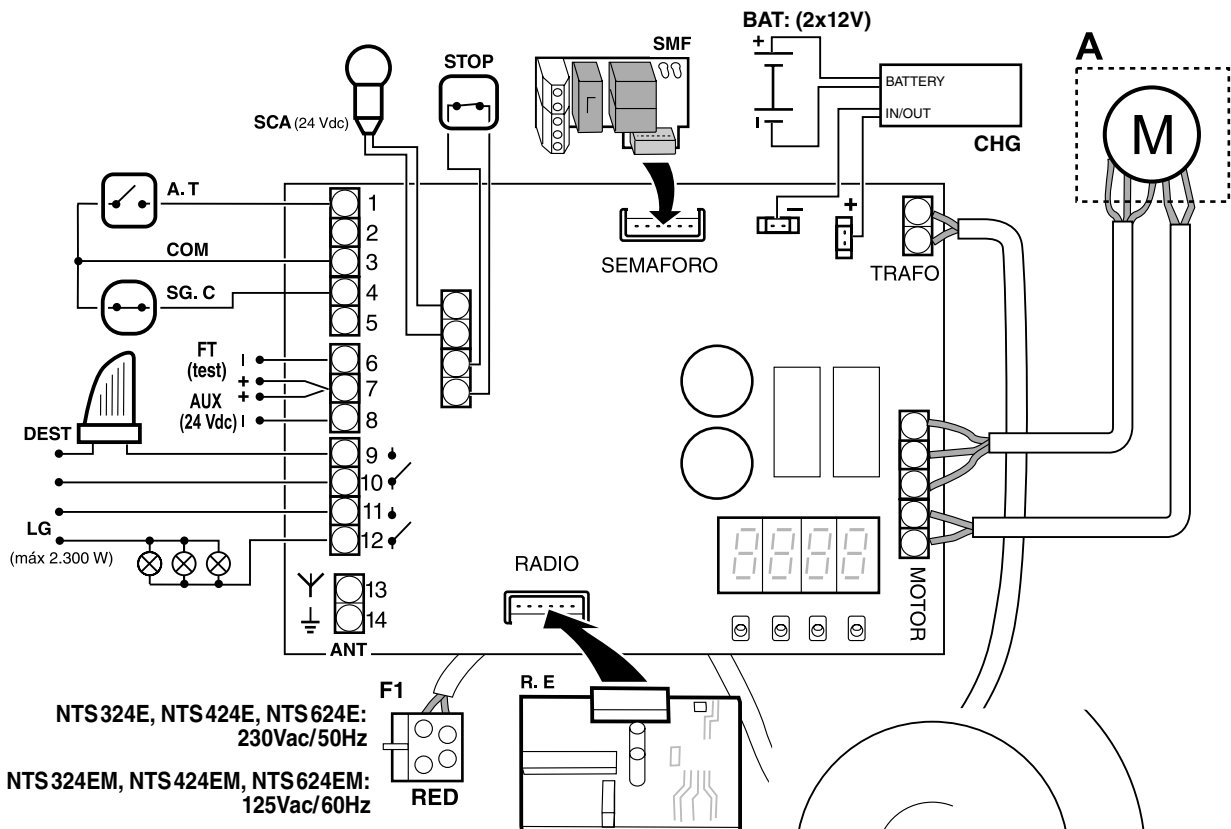

P136F

Hlášení na display

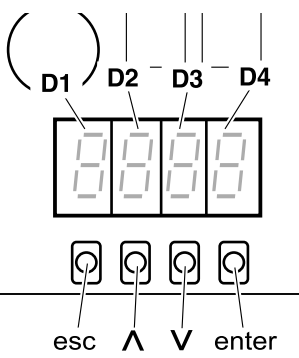

D1 a D2:

CL (stále)	Závora je uzavřena
CL (blikající)	Závora se zavírá
OP (stále)	Závora je otevřená
OP (blikající)	Závora se otevírá
XX (zpětný odpočet)	Závora je v pohotovosti
STOP	Aktivátor je odblokovaný
PA (stále)	Pauza (úkon nebyl ukončen)
RS (stále)	Závora vyhledává polohu pro uzavření

D3 a D4:

CS	Bezpečnostní zařízení pro zavírání je aktivováno
E I	Kodér motoru je zastavený
F I	Převýšen limit pro zátěž
BA	Baterie v provozu
Ft no	Závada na fotobuňkách (zkouška)

Změna směru pohybu (I)

Tato operace je nutná jen v případě, že se závora při resetování (r5), namísto zavření otevře.

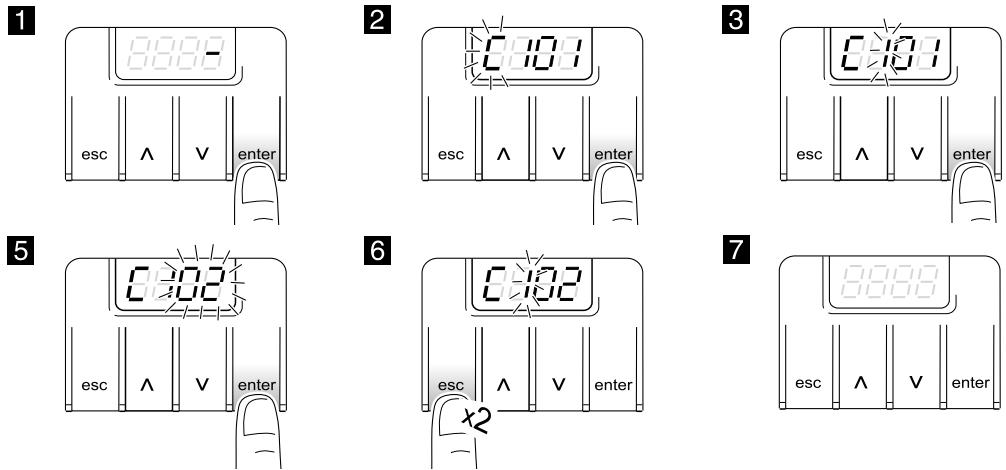

P58G

Programování rádiového kódu, P (pouze s přijímačem RSD)

Je-li používán přijímač jiný než RSD, vizte příslušné pokyny.

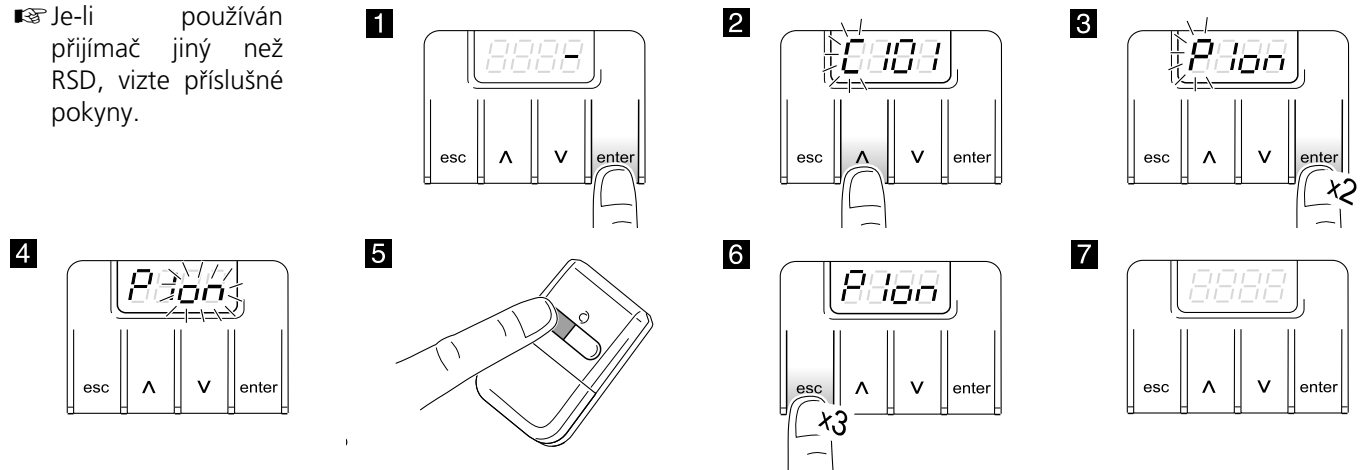

Pro správné fungování závory je nezbytné provést záznam její provozní dráhy

Záznam provozní dráhy (P3)

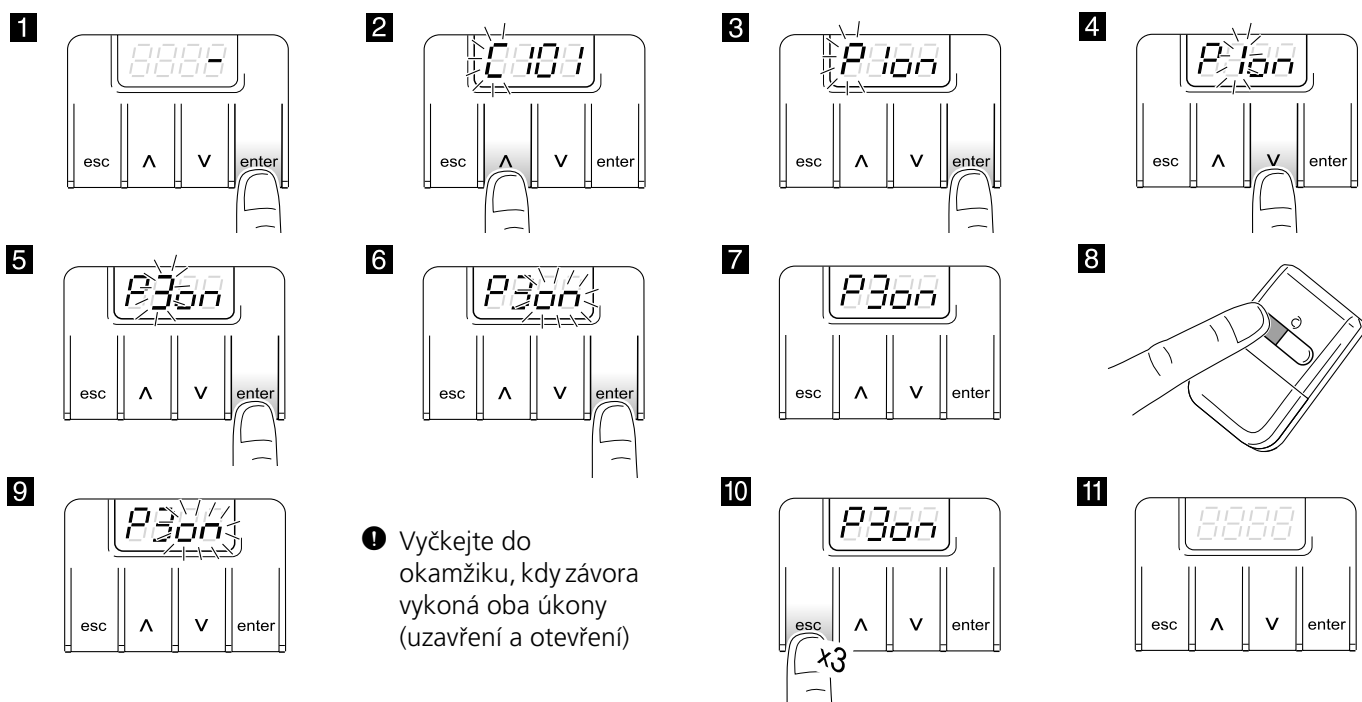

Tabulka pro programování

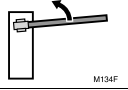
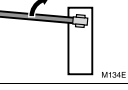
D1	D2	Parametr	D3	D4	Volba předem nastavena	Možnosti a hodnoty
C	1	Směr otáčení motoru	0	1	x	
			0	2		
	4					Deaktivováno
	5	Bezpečnostní zařízení pro uzavření (fotobuňka či bezpečnostní lišta)	0	0	x	Zařízení není instalováno
			1	0		Zařízení bez přezkoušení
			1	1		Zařízení s přezkoušením
P	1	Záznam rádiového kódu pro úplné otevření	o	n		
	2					Deaktivováno
	3	Záznam provozní dráhy závory	o	n		
F	1	Způsob provozu	0	1		Automatický
			0	2	x	Poloautomatický
	2	Pohotovostní doba u automatického způsobu	0...5.	0...9.	15	59 = 59 vteřin; 2.5 = 2 minut. 50 vteřin apod.
	3				Deaktivováno	
R	0	Blikající světlo (maják)	0	1	x	Bez předběžného upozornění
			0	2		S předběžným upozorněním
	1	Doba osvětlení garáže	0...5.	0...9.	03	59 = 59 vteřin; 2.5 = 2 minut. 50 vteřin apod.
	2	Rychlost závory	0	1...5.	03	0 1: minimální rychlost; 05: maximální rychlost
	3	Rychlost zpomalování při zavírání	0	1...5.	02	0 1: minimální rychlost; 05: maximální rychlost
	4	Vzdálenost pro zpomalování při zavírání	0	0...5.	00	00: minimální vzdálenost; 05: maximální vzdálenost
	5					Deaktivováno
	6	Maximální síla	0... 1	0...9.	05	0 1: minimální síla; 10: maximální síla
	7	Pohyb před fotobuňkou v průběhu pohotovostní doby (pouze u automatického způsobu)	0	1		Okamžité uzavření
			0	2	x	Znovuzapočetí pohotovostní doby
			0	3		Bez efektu
	8	Stisknutí tláčítka v průběhu pohotovostní doby (pouze u automatického způsobu)	0	1		Okamžité uzavření
			0	2	x	Znovuzapočetí pohotovostní doby
0			3		Bez efektu	
9	Způsob otevírání	0	1	x	Otevírání stejným způsobem, který byl zvolen u základních funkcí (F)	
		0	2		Kolektivní otevírání (kontrolní panel při otevření nereaguje na pokyny z ovladače)	
		0	3		Otevírání krok za krokem (Při stisknutí jakéhokoliv ovládacího zařízení při otevírání, se závora zastaví Při jakémkoliv další aktivaci se závora zavře)	
n	1	Provedené úkony	X	X		Udává provedené cykly, přičemž je uvedená cifra násobena určitým množstvím úkonů. Například: - slo 68 udává 6800 provedených cyklů - slo 6.8 udává 68 000 provedených cyklů

**NOTĂ
IMPORTANTĂ**

Acest ghid rapid este un rezumat al manualului de instalare completă. Manualul conține avertismentele de siguranță și alte explicații care trebuie să fie luate în considerare. Manualul de instalare poate fi descărcat mergând la secțiunea "Downloads" de pe site-ul Erreka: <http://www.erreka-automation.com>

Elemente de instalare completă

Cablarea electrică

- A: Sursa de alimentare electrică
- B: Lumină intermitentă
- C: Fotelule (Tx / Rx)
- D: Comutator cu cheie

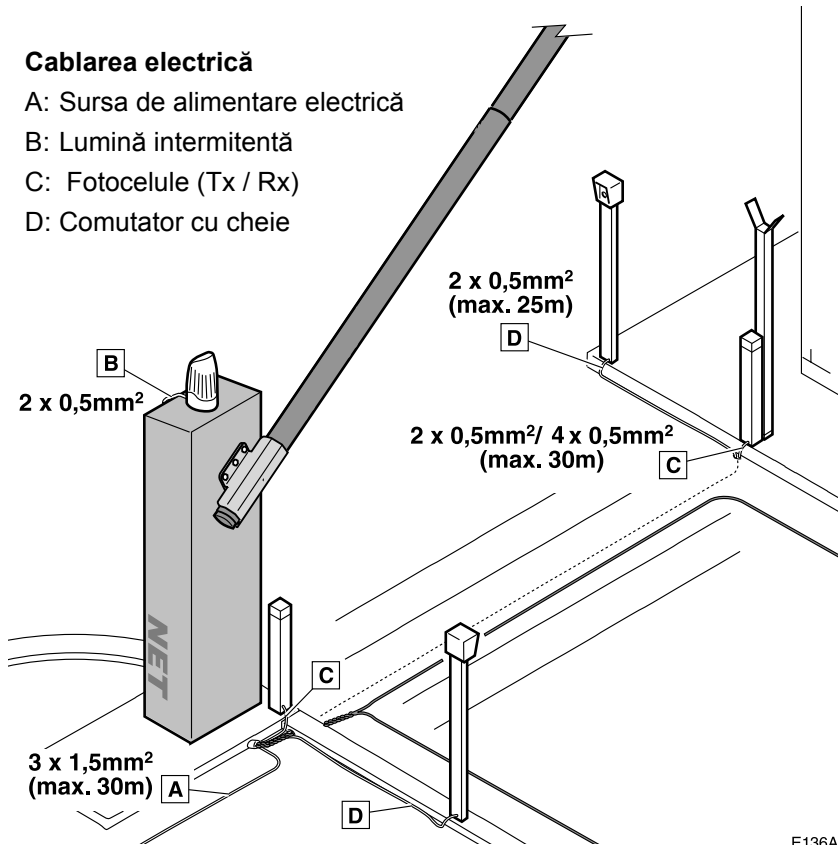

E136A

Deblocare

▲ Deblocarea trebuie să fie realizată cu precauție. Dacă bariera nu este echilibrată sau dacă brațul nu este montat, resortul interior poate provoca o deplasare violentă.

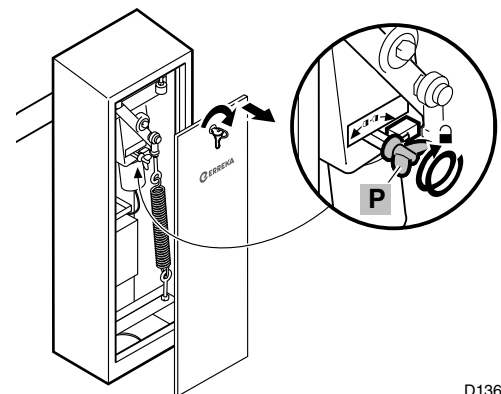

D136A

Deblocare (funcționare manuală):
roțiți piulița fluture (P) în sensul acelor de ceasornic până când se oprește.

Blocare (funcționare motorizată):
roțiți piulița fluture (P) în sens contrar acelor de ceasornic până când se blochează.

Montajul brațului

Bariera este furnizată pentru montajul pe partea dreaptă. Pentru montajul pe partea stângă, înainte de a monta brațul, efectuați "Schimbarea părții" (a se vedea pagina următoare)

- 1 Blocați elementul de acționare și montați prima secțiune.
- 2 Deblocați elementul de acționare și coborâți manual brațul.
- 3 Blocați elementul de acționare și montați a doua secțiune.

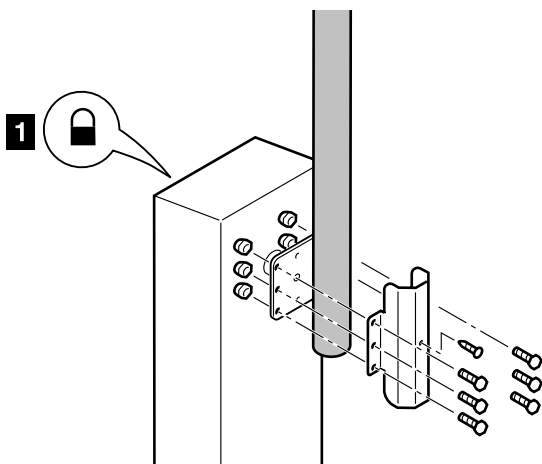

P136C1

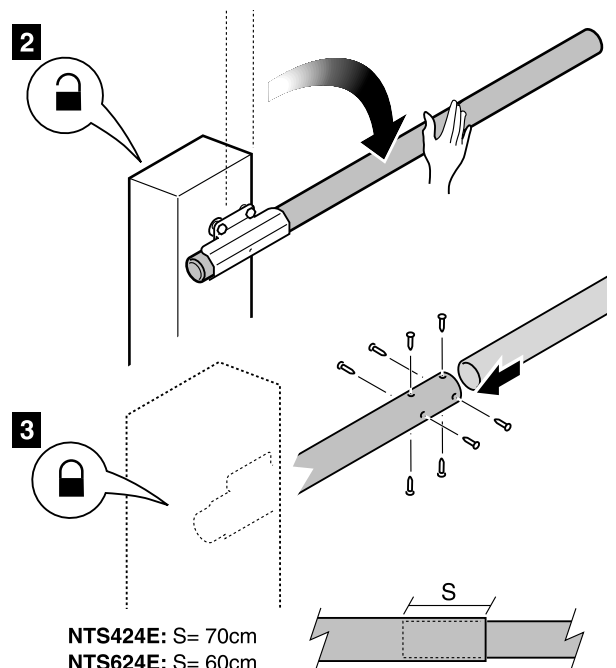

NTS424E: S= 70cm
NTS624E: S= 60cm

P136C2

Schimbarea părții

Bariera dreaptă

Bariera stângă

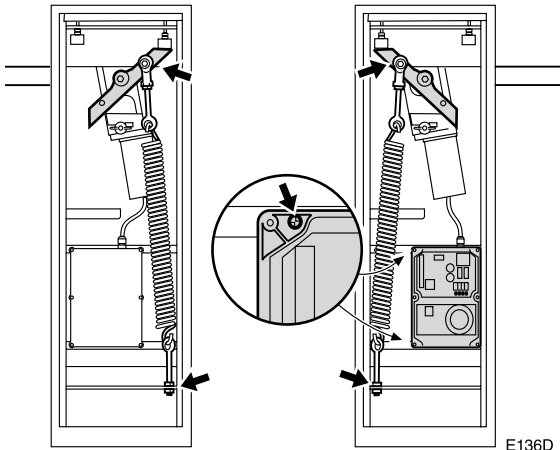

E136D

Echilibrarea

PENTRU O FUNCȚIONARE CORESPUNZĂTOARE, BARIERA TREBUIE SĂ FIE ECHILIBRATĂ.

- Deblocați elementul de acționare și strângeți resortul până când bariera este echilibrată la 45°.

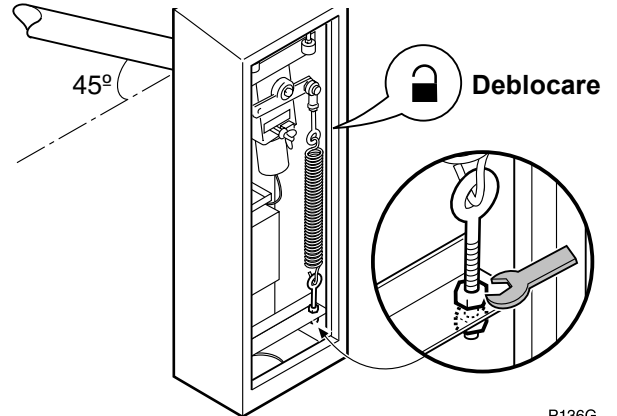

P136G

Conexiuni generale

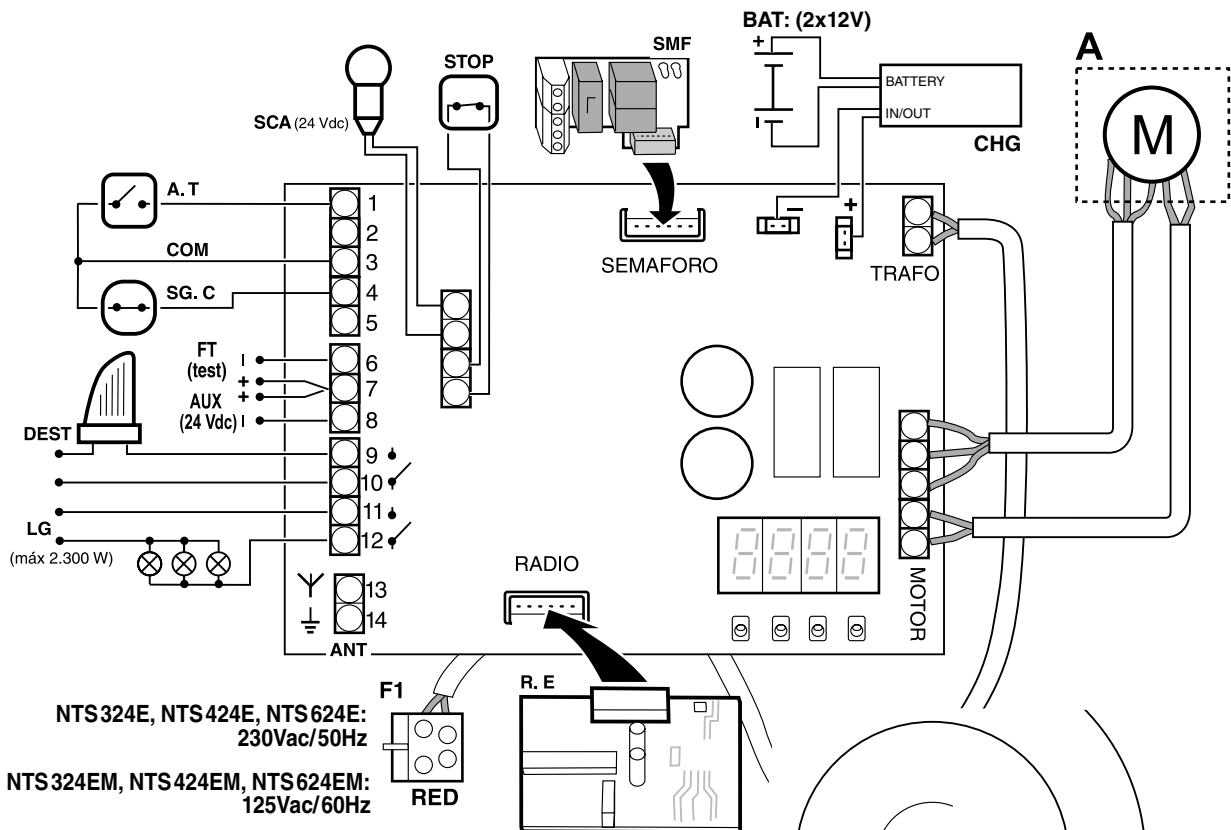

P136F

Indicațiile afișajului

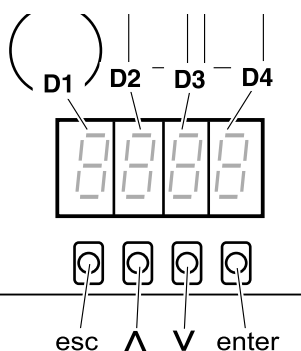

D1 și D2:

⌊ L (fix)	Barieră închisă
⌊ L (intermitent)	Barieră în curs de închidere
OP (fix)	Barieră deschisă
OP (intermitent)	Barieră în curs de deschidere
XX (numărătoare inversă)	Barieră în așteptare
S t OP	Element de acționare deblocat
PR (fix)	Pauză (manevră neterminată)
r S (fix)	Bariera în curs de căutare a poziției de închidere

D3 și D4:

⌊ S	Dispozitiv de securitate la închidere activat
E I	Encoder motor oprit
F I	Limita forței depășită
b R	Baterie în funcționare
F t n o	Fotocelule defecte (test)

Schimbarea sensului de rotație (L I)

☞ Această operație este necesară numai dacă bariera se deschide în loc să se închidă atunci când se face o reanclanșare (r-5).

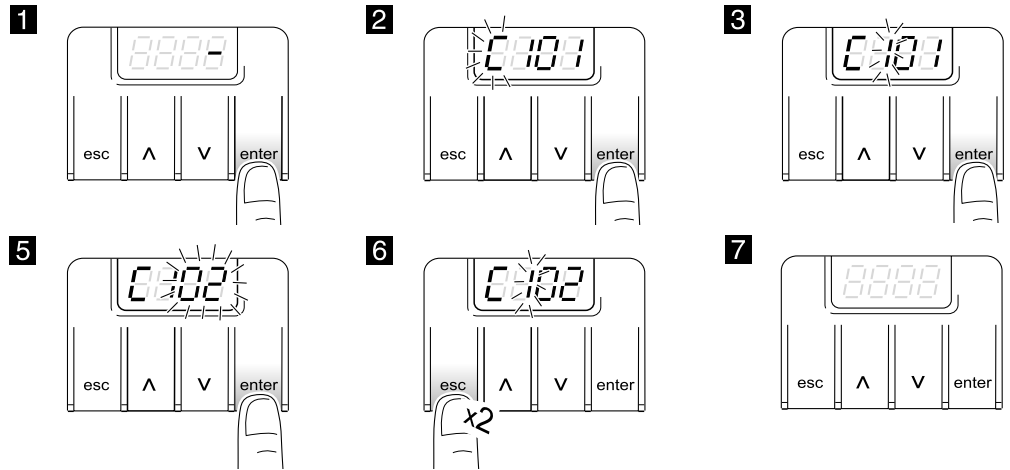

P58G

Programarea codului radio, P I (doar cu receptor RSD)

☞ Dacă este utilizat un alt receptor decât RSD, a se consulta instrucțiunile corespunzătoare.

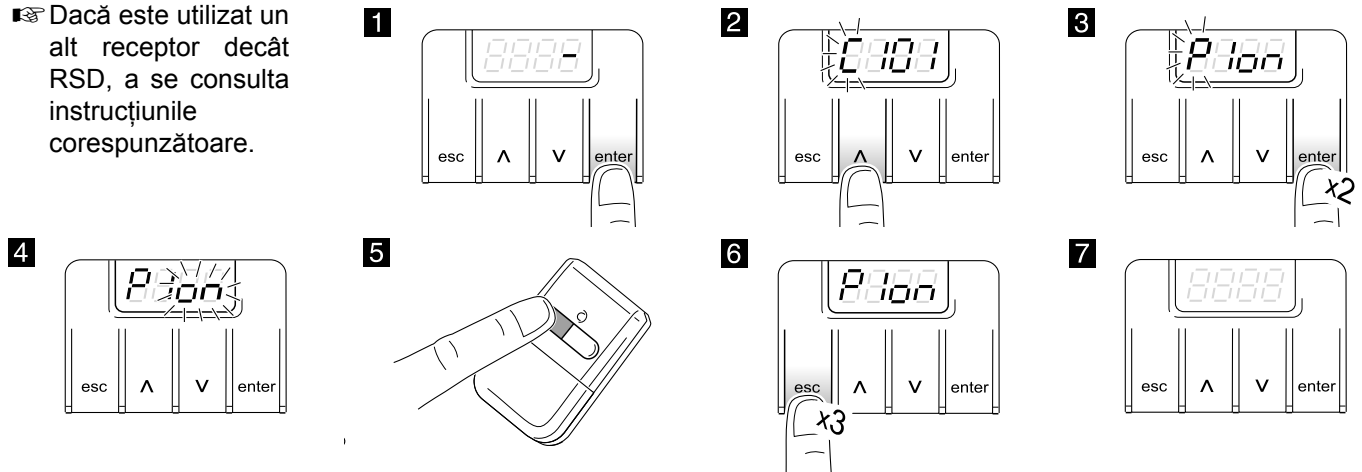

Pentru funcționarea corespunzătoare a barierei, trebuie neapărat programat parcursul acesteia.

Programarea parcursului de deschidere/închidere (P3)

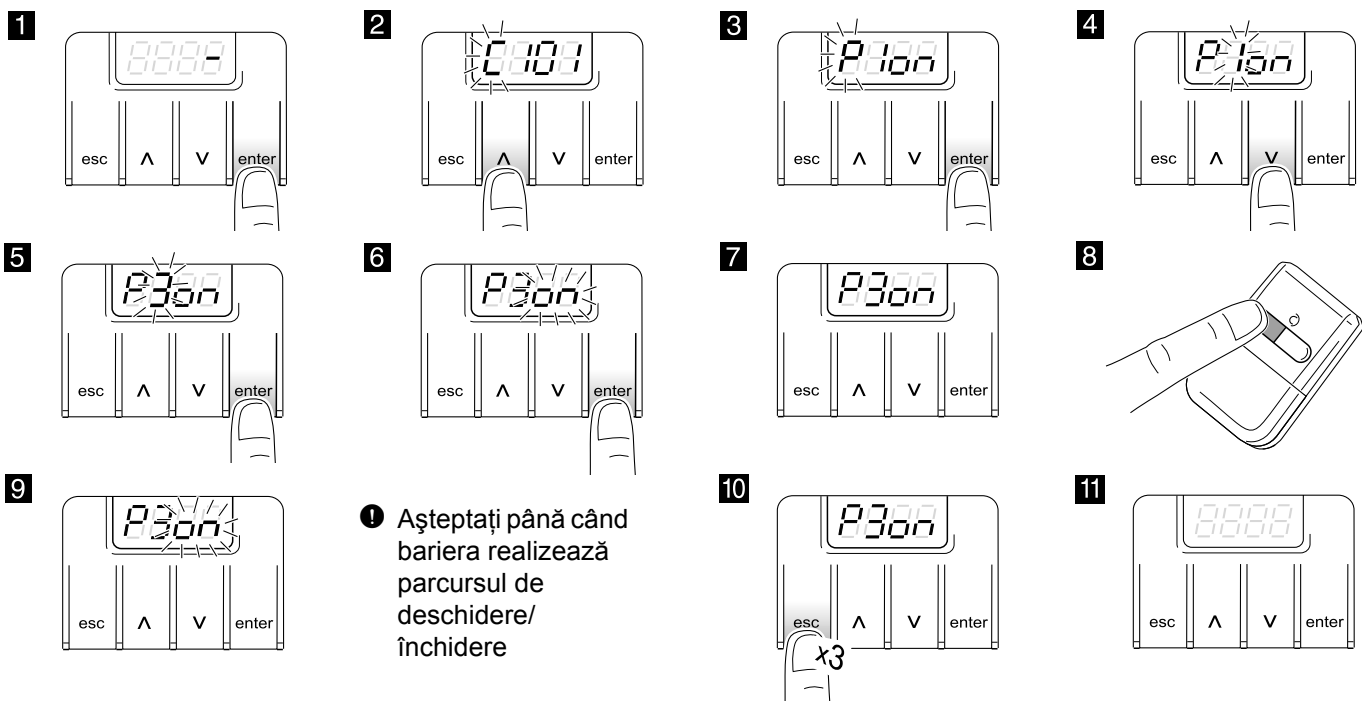

Tabel de programare complet

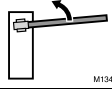
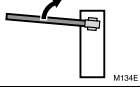
D1	D2	Parametru	D3	D4	Opțiune predeterminată	Opțiuni sau valori
C	1	Sensul de rotație a motorului	0	1	x	
			0	2		
	4				Dezactivat	
	5	Dispozitiv de siguranță la închidere (fotocelulă sau bandă)	0	0	x	Dispozitiv neinstalat
			1	0		Dispozitiv fără testare
1			1		Dispozitiv cu testare	
P	1	Programare cod radio pentru deschidere totală	0	0		
	2					Dezactivat
	3	Programarea parcurșului de deschidere/închidere a barierei	0	0		
F	1	Modul de funcționare	0	1		Automat
			0	2	x	Semiautomat (Progresiv)
	2	Timp de așteptare în mod automat	0...5	0...9	15	59 = 59 sec.; 2.5 = 2 min. 50 sec., etc
	3					Dezactivat
R	0	Lumină intermitentă	0	1	x	Fără avertizare
			0	2		Cu avertizare
	1	Timpul de lumină a garajului	0...5	0...9	03	59 = 59 sec.; 2.5 = 2 min. 50 sec., etc
	2	Viteza barierei	0	1...5	03	01: viteza minimă; 05: viteza maximă
	3	Viteza de încetinire	0	1...5	02	01: viteza minimă; 05: viteza maximă
	4	Distanța de încetinire	0	0...5	00	00: distanța minimă; 05: distanța maximă
	5					Dezactivat
	6	Forța maximă	0...1	0...9	05	01: forța minimă; 10: forța maximă
	7	Închidere fotocelulă utilizată pe parcurșul timpului de așteptare (doar în modul automat)	0	1		Închidere imediată
			0	2	x	Reîncepe timpul de așteptare
			0	3		Nu are efect
8	Buton acționat pe parcurșul timpului de așteptare (doar în modul automat)	0	1		Închidere imediată	
		0	2	x	Reîncepe timpul de așteptare	
		0	3		Nu are efect	
9	Modul de deschidere	0	1	x	Deschidere în conformitate cu modul selectat în funcțiile principale (F)	
		0	2		Deschidere comunitară (panoul de comandă nu răspunde la comenzile de la cheie în timpul deschiderii)	
		0	3		Deschidere progresivă (poarta se oprește dacă un dispozitiv cu cheie este acționat în timpul deschiderii. Barierea se închide dacă acesta este activat din nou)	
n	1	Manevre realizate	X	X		Indică ciclurile realizate, multiplicând cifra indicată cu o cantitate, de exemplu: 68 indică 6.800 cicluri realizate 6.8 indică 68.000 cicluri realizate

ПРЕДУПРЕЖДЕНИЕ

Данное краткое руководство является сжатым изложением полной инструкции по установке. Упомянутая инструкция включает в себя замечания по безопасности и другие необходимые пояснения. Инструкцию по установке можно загрузить из раздела Descargas (Загрузить) на веб-сайте Erreka: <http://www.erreka-automation.com>

Элементы полной установки

Кабельная проводка

- A: общее питание
- B: сигнальная лампа
- C: фотодатчики (Tx/Rx)
- D: ключевой выключатель

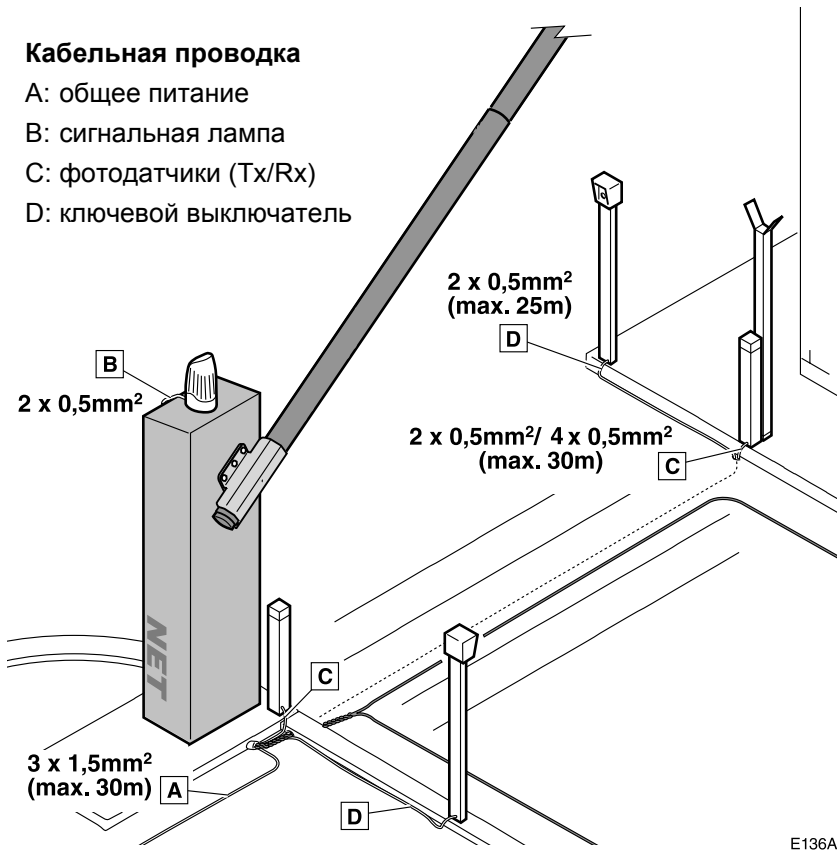

E136A

Разблокировка

▲ При разблокировке следует соблюдать меры предосторожности. Если шлагбаум не сбалансирован, или не установлена стрела, движение внутренней пружины может привести к резкому смещению.

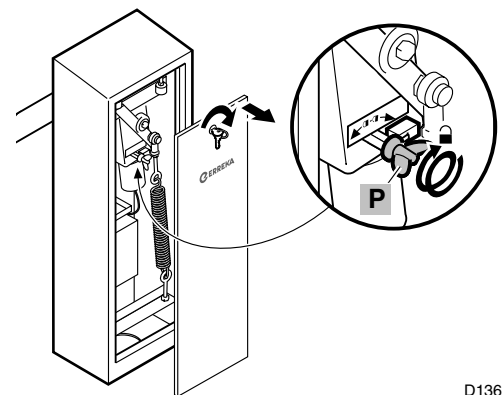

D136A

Разблокировка (ручной привод): проверните барашек (P) вправо до упора.

Блокировка (механический привод): проворачивайте барашек (P) влево до достижения блокировки.

Установка стрелы

■ Шлагбаум поставляется собранным под установку с правой стороны. При необходимости установки с левой стороны, следует сперва выполнить операции, описанные в пункте "Смена стороны" (см. следующую страницу).

- 1 Заблокировать привод и установить первую секцию.
- 2 Разблокировать привод и опустить стрелу вручную.
- 3 Заблокировать привод и установить вторую секцию.

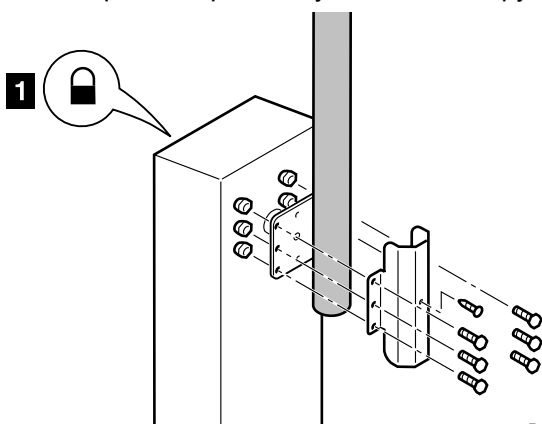

P136C1

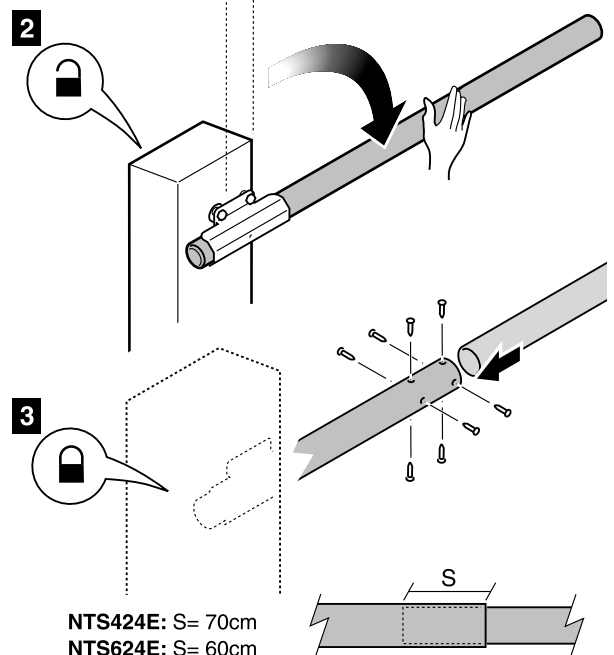

NTS424E: S= 70cm
NTS624E: S= 60cm

P136C2

Смена стороны

Правосторонний
шлагбаум

Левосторонний
шлагбаум

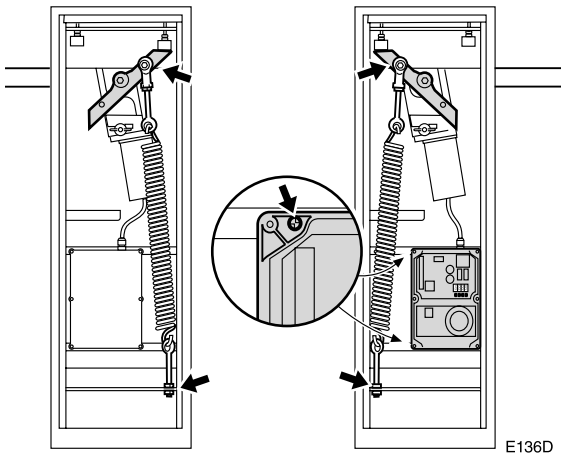

E136D

Балансировка

■ **ДЛЯ ПРАВИЛЬНОЙ РАБОТЫ, ШЛАГБАУМ НЕОБХОДИМО СБАЛАНСИРОВАТЬ.**

- Разблокируйте привод и натягивайте пружину до тех пор, пока стрела не станет под углом 45°.

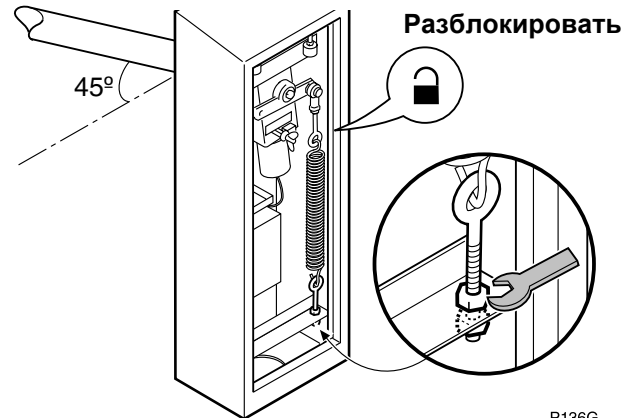

P136G

Общее подключение

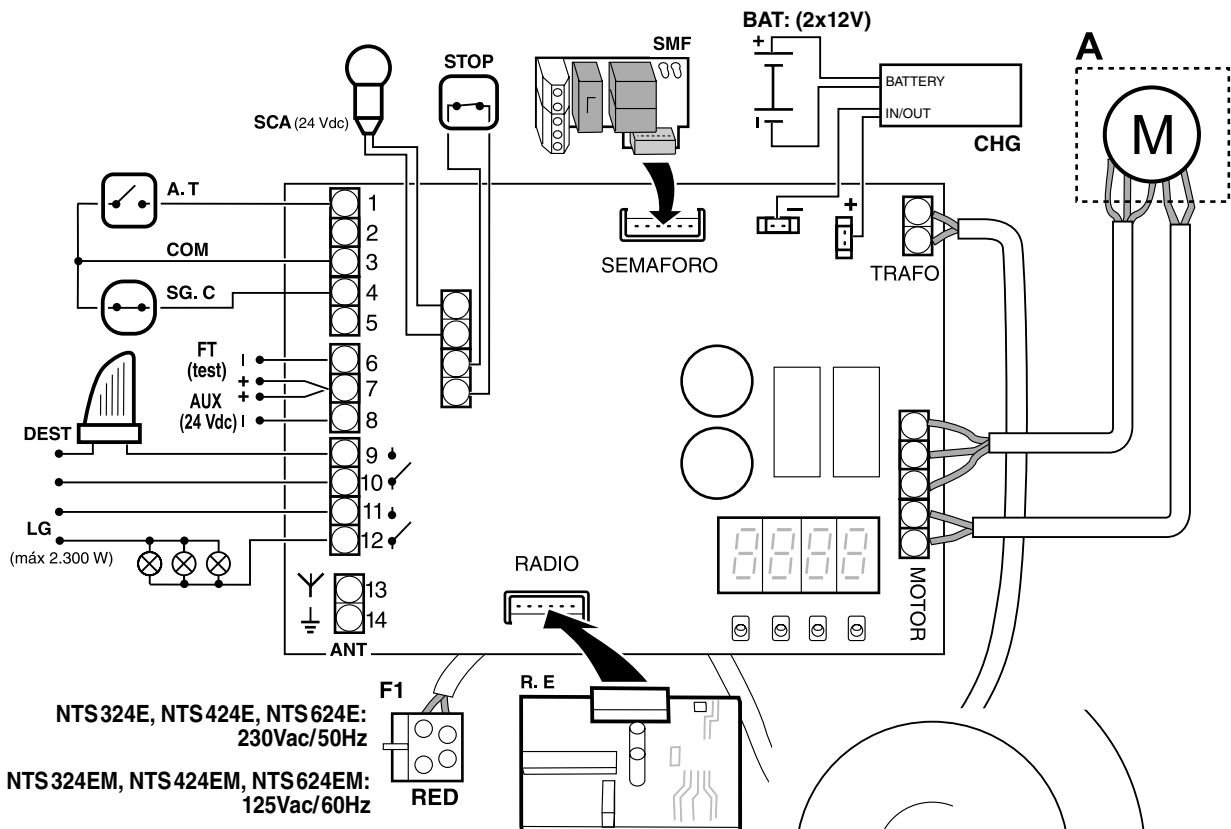

P136F

Индикация на дисплее

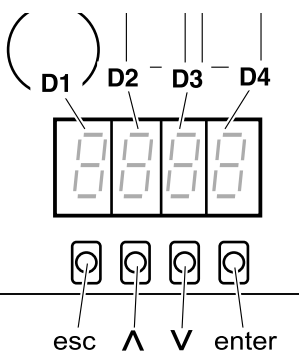

D1 и D2:

- ⌚ (горит не мигая) шлагбаум закрыт
- ⌚ (мигает) шлагбаум закрывается
- OP (горит не мигая) шлагбаум открыт
- OP (мигает) шлагбаум открывается
- XX (обратный отсчет) шлагбаум в ожидании
- STOP привод разблокирован
- PA (горит не мигая) пауза (движение не завершено)
- ⌚ (горит не мигая) шлагбаум в поисках закрытого положения

D3 и D4:

- ⌚ защитное устройство закрытия активировано
- E I датчик останова мотора
- F I предел усилия превышен
- BA батарея в работе
- F no фотодатчики неисправны (тестирование)

Смена направления вращения (C I)

Данная операция необходима, только если шлагбаум после перезагрузки (-5) открывается, вместо того чтобы закрываться.

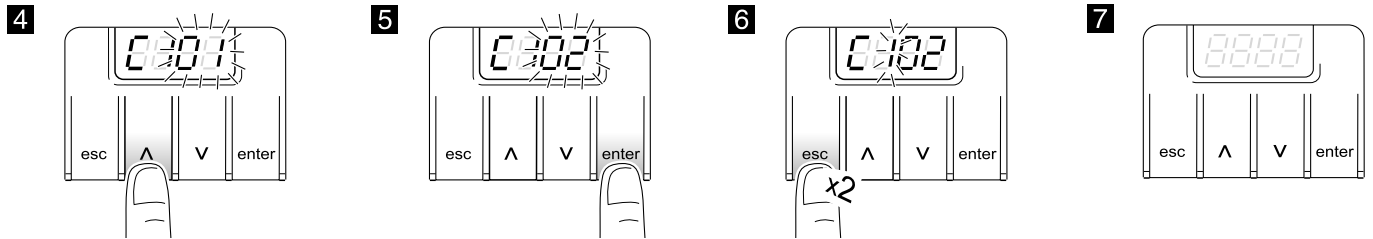

P58G

Регистрация радиосигнала, P I (только приемником RSD)

При использовании другого приемника, отличного от RSD, необходимо ознакомиться с его инструкцией.

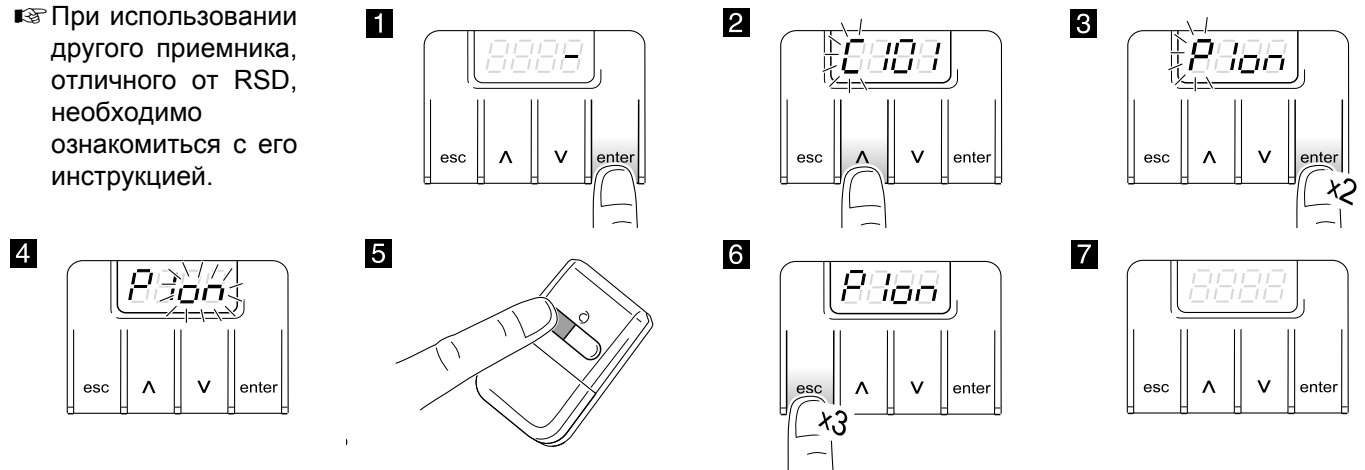

Для правильной работы шлагбаума необходимо произвести регистрацию проходов

Регистрация проходов (P3)

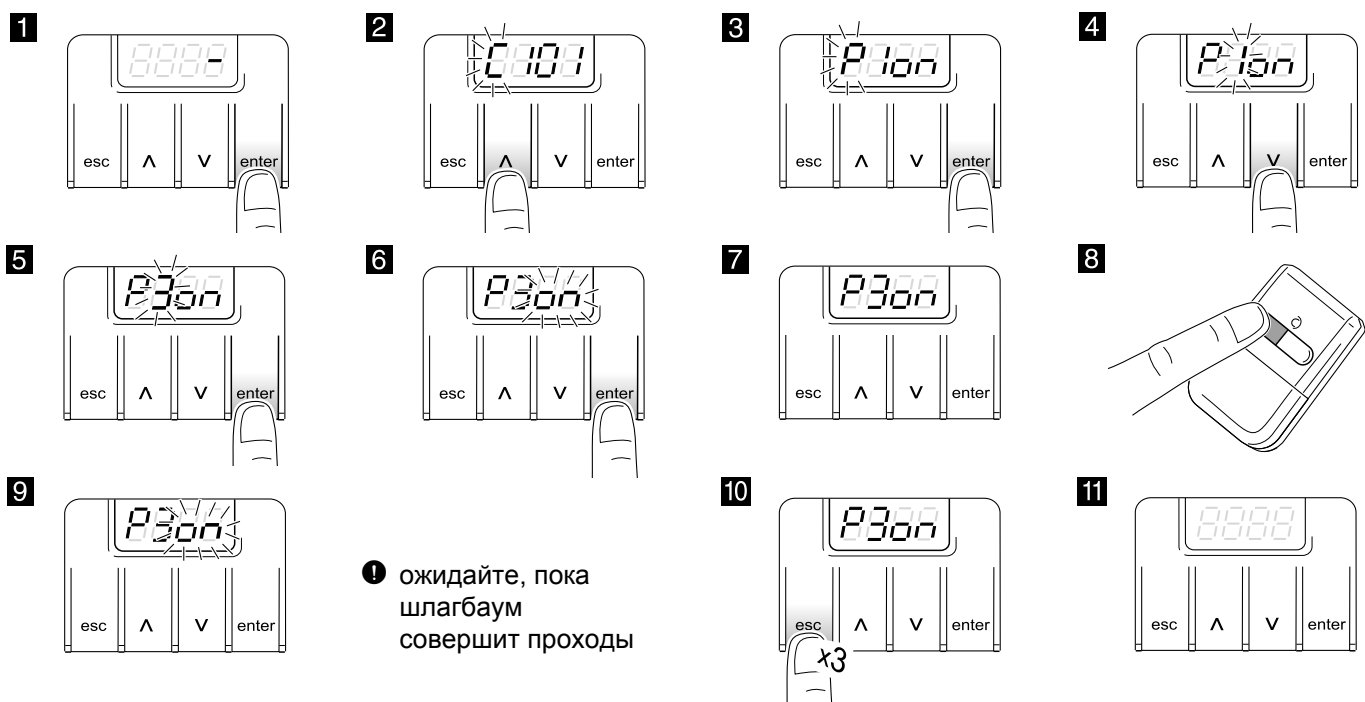

Полная таблица программирования

D1	D2	Параметр	D3	D4	Предустановленная опция	Опции или значения
C	1	Направление вращения мотора	0	1	x	
			0	2		
	4					Отключено
	5	Защитное устройство закрытия (фотоэлемент или полоса)	0	0	x	
1			0			Устройство без тестирования
1			1			Устройство с тестированием
P	1	Регистрация радиосигнала полного открытия	o	n		
	2					Отключено
	3	Регистрация прохода шлагбаума	o	n		
F	1	Режим работы	0	1		Автоматический
			0	2	x	Полуавтоматический
	2	Время ожидания в автоматическом режиме	0...5.	0...9	15	59 = 59 сек; 2.5 = 2 мин 50 сек и т. д.
	3					Отключено
Я	0	Сигнальная лампа	0	1	x	Без предупреждения
			0	2		С предупреждением
	1	Время освещения гаража	0...5.	0...9	03	59 = 59 сек; 2.5 = 2 мин 50 сек и т. д.
	2	Скорость шлагбаума	0	1...5	03	01: минимальная скорость; 05: максимальная скорость
	3	Скорость при мягкой остановке	0	1...5	02	01: минимальная скорость; 05: максимальная скорость
	4	Расстояние при мягкой остановке	0	0...5	00	00: минимальное расстояние; 05: максимальное расстояние
						Отключено
	6	Максимальное усилие	0...1	0...9	05	01: минимальное усилие; 10: максимальное усилие
	7	Проход по фотодатчику закрытия в течение времени ожидания (только в автоматическом режиме)	0	1		Немедленное закрытие
			0	2	x	Повтор времени ожидания
			0	3		Не производит действия
	8	Задействование кнопочного выключателя в течение времени ожидания (только в автоматическом режиме)	0	1		Немедленное закрытие
			0	2	x	Повтор времени ожидания
0			3		Не производит действия	
9	Режим открытия	0	1	x	Открытие согласно режиму, выбранному в главных функциях (F)	
		0	2		Общее открытие (во время открытия панель управления не подчиняется командам движения)	
		0	3		Пошаговое открытие (если во время открытия срабатывает какое-либо устройство движения, шлагбаум приостанавливается. Если такое устройство срабатывает снова, шлагбаум закрывается.)	
n	1	Проделанные операции	X	X		Показывает количество проделанных рабочих циклов. Отображаемую цифру следует умножить на определенное число, например: 58 показывает, что шлагбаум проделал 6800 рабочих циклов 5.8 показывает, что шлагбаум проделал 68 000 рабочих циклов

هذا الدليل السريع هو ملخص لدليل التركيب الكامل. هذا الدليل يحتوي على تنبيهات الأمان و الإيضاحات الأخرى التي يجب أخذها بالاعتبار. يمكنكم تحميل دليل التركيب من الفقرة "تحميلات" من موقع Erreka:

<http://www.erreka.com/Automatismos/descargaDocumentos.aspx>

تنبيه

عناصر التركيب الكامل

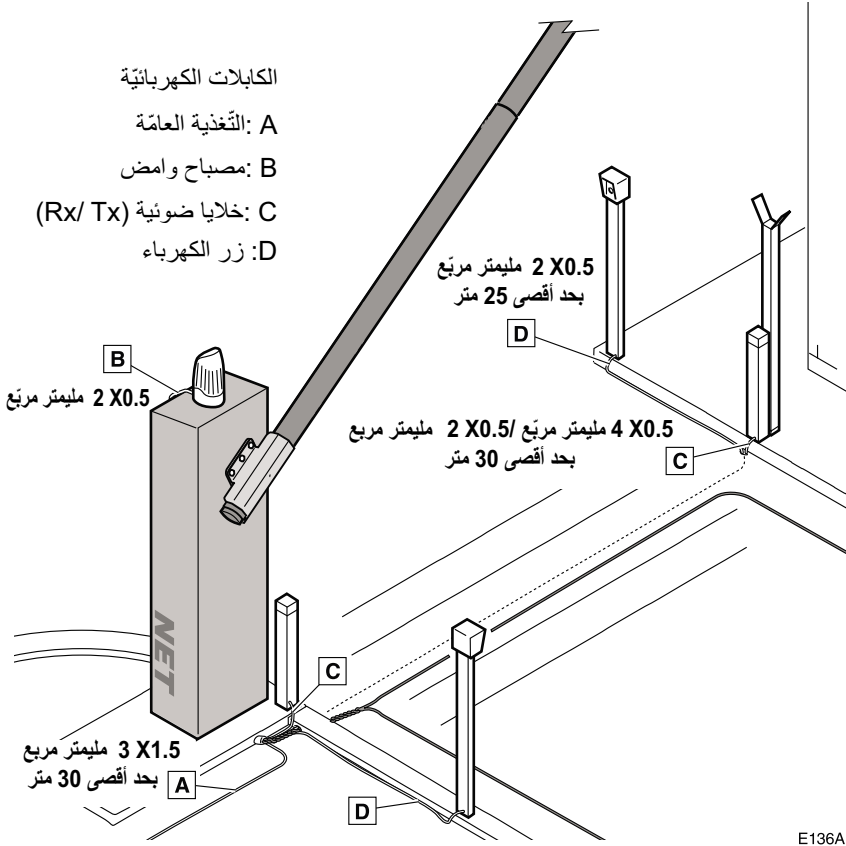

E136A

التحرير

⚠ يجب توخي الحذر عند إجراء التحرير. لو أنّ القضيبي غير متوازن أو الذراع غير مُركب، فإنّ الزنبرك الداخلي يمكنه أن يتسبب في إزاحة عنيفة.

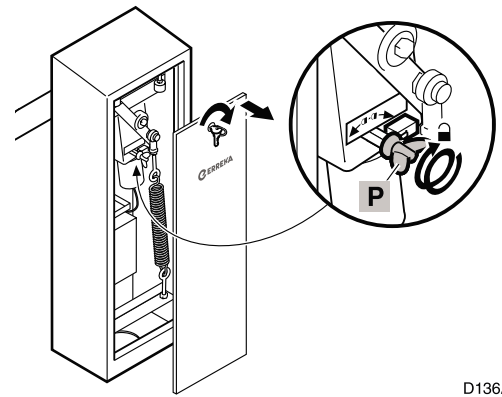

D136A

التحرير (تشغيل يدوي):
أدر المفتاح (P) إلى اليمين حتى الحد الأقصى للدوران.
الكبح (تشغيل آلي):
أدر المفتاح (P) إلى اليسار حتى تحصل على الكبح.

تركيب الذراع

يتم توفير القضيبي للتركيب على اليمين. لو أنّك ترغب في تركيبه على الشمال، عليك بعمل "تغيير للجانب" قبل تركيب الذراع (انظر الصفحة التالية).

- 1 كبح المُشغل و تركيب المرحلة الأولى.
- 2 تحرير المُشغل و انزال الذراع يدويًا.
- 3 كبح المُشغل و تركيب المرحلة الثانية.

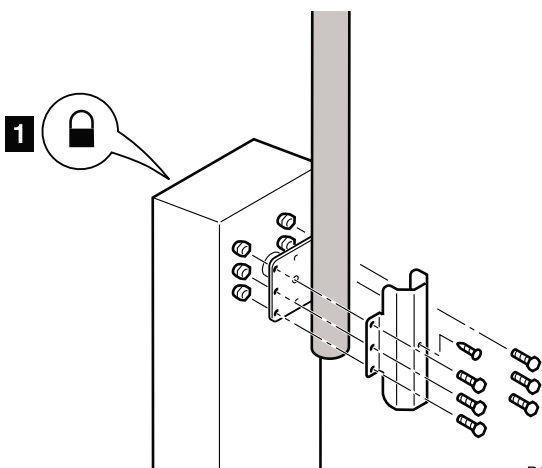

P136C1

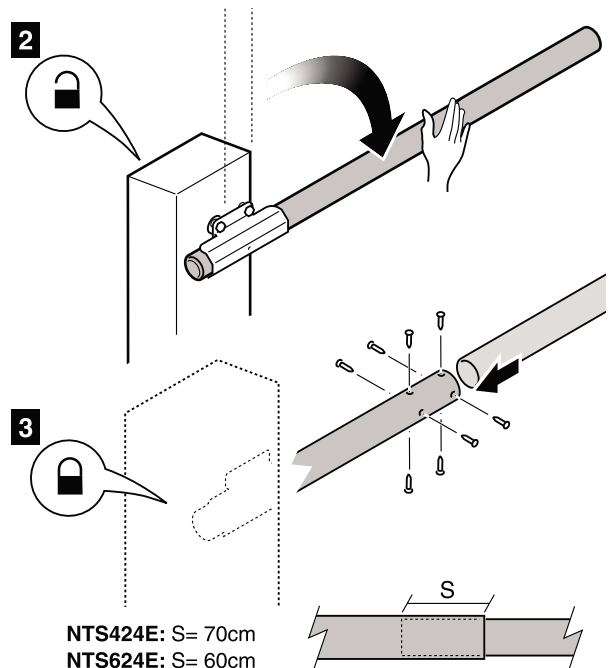

NTS424E: S= 70cm
NTS624E: S= 60cm

P136C2

تغيير الجانب

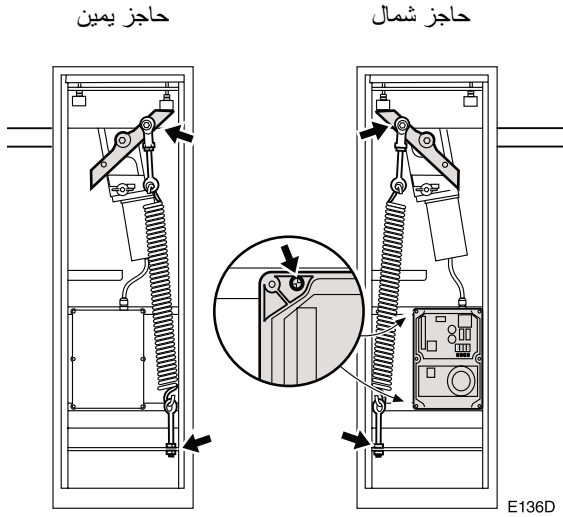

الموازنة

- للأداء الصحيح ، لا بد من موازنة القضيب.
- قم بتحرير المُشغّل وشدّ الزنبرك حتى يبقى القضيب في وضع متوازن في 45°.

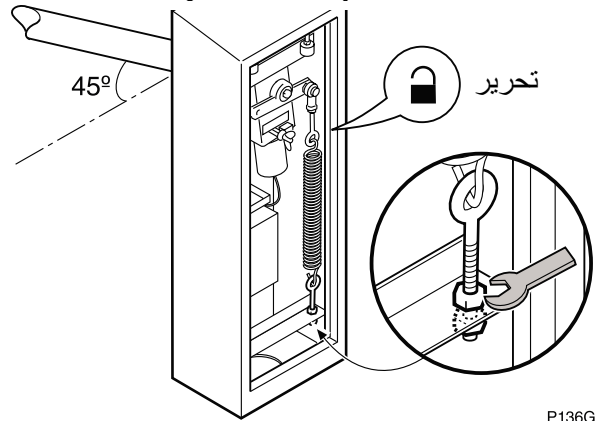

التوصيلات العامة

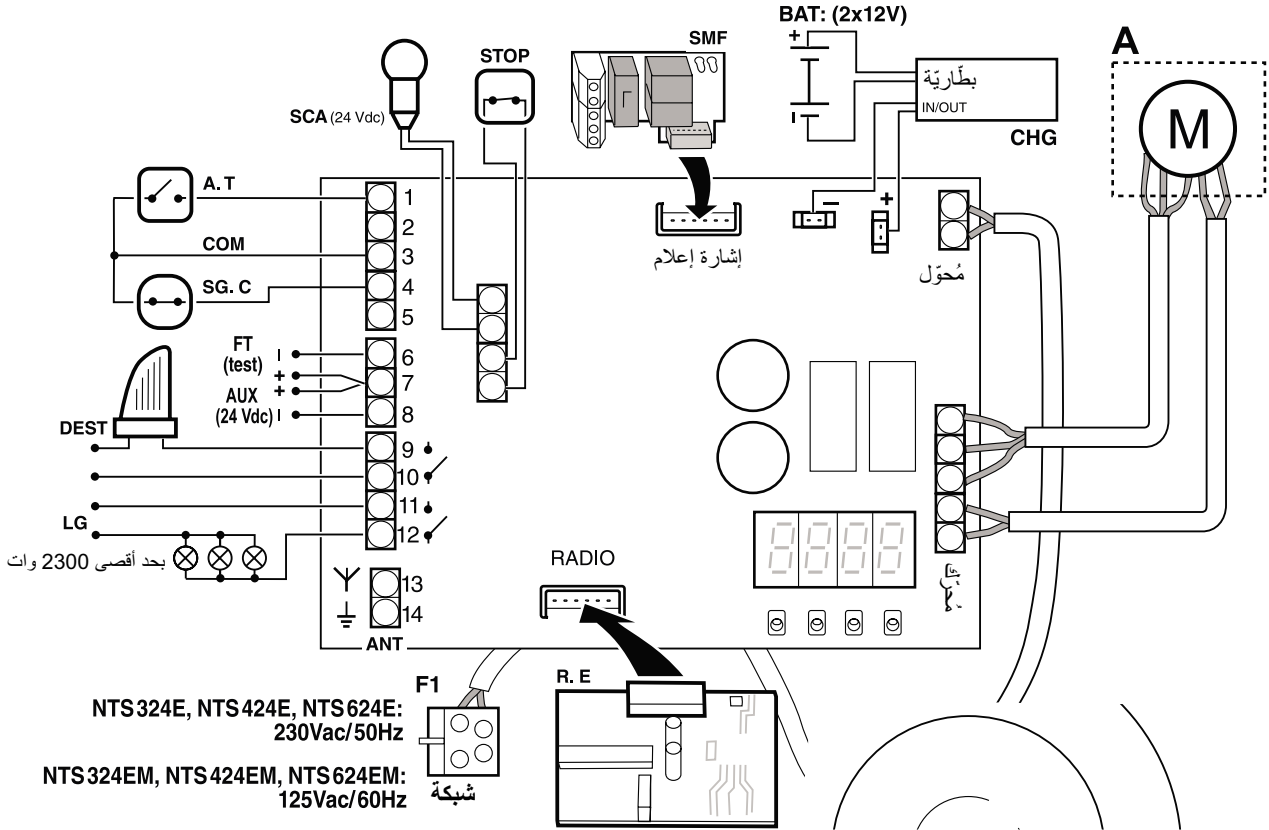

إشارات العرض

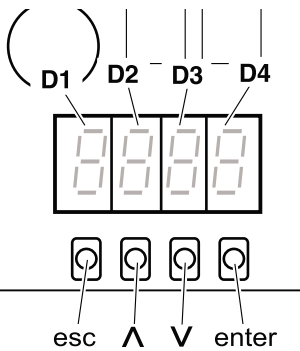

بؤابة مغلقة	D1 و D2 : (ساكن)
بؤابة يتم غلقها	D1 و D2 : (وا مض)
بؤابة مفتوحة	D3 و D4 : (ساكن)
بؤابة يتم فتحها	D3 و D4 : (وا مض)
بؤابة في وضع الانتظار	XX (عد تنازلي)
مُشغّل مُحَرَّر	STOP
توقّف (عملية غير مُكتملة)	PR (ساكن)
بؤابة تبحث عن وضع الإغلاق	rs (ساكن)

D3 و D4 :	CS
D3 و D4 :	جهاز أمان الإغلاق مُفعل
D3 و D4 :	E I
D3 و D4 :	مُشغّل المُحرّك مُوقف
D3 و D4 :	F I
D3 و D4 :	حد قوّة الدفع مُتجاوز
D3 و D4 :	bR
D3 و D4 :	البطارية في وضع عمل
D3 و D4 :	Ftno
D3 و D4 :	خلايا ضوئية معيبة (اختبار)

تغيير اتجاه الدوران (I)

هذه العملية ضرورية فقط لو أن القضيبي عند عمل إعادة تعيين (r5) ، يُفتح بدلا من أن يُغلق.

1

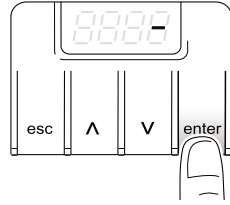

2

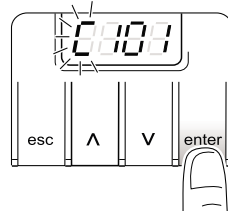

3

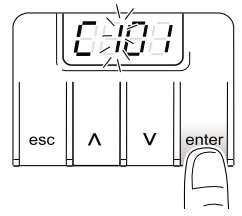

4

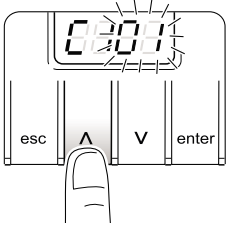

5

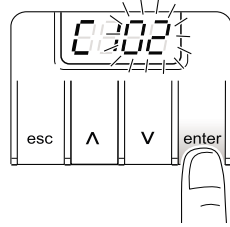

6

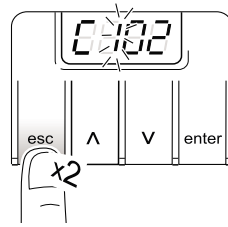

7

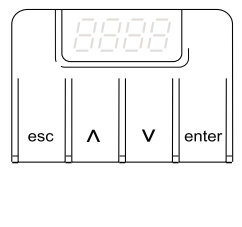

P58G

تسجيل كود أو شفرة الراديو ، P (فقط مع مُستقبل RSD)

لو أنك تستخدم مُستقبل مُختلف عن RSD ، عليك بمراجعة تعليماته الخاصة.

1

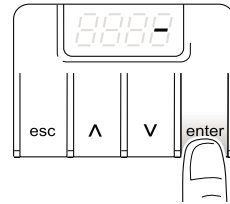

2

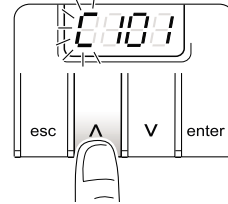

3

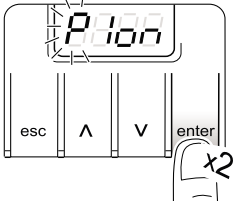

4

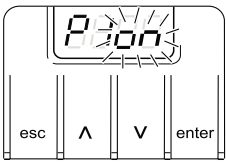

5

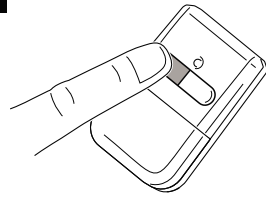

6

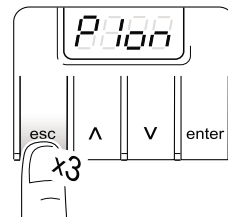

7

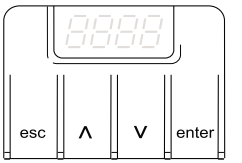

لحسن أداء القضيبي لا غنى عن عمل تسجيل للمسار

تسجيل المسار (P3)

1

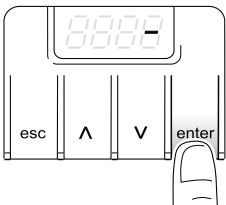

2

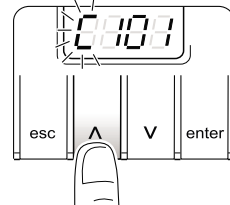

3

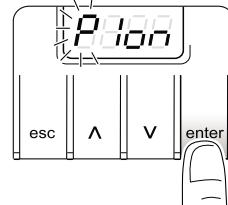

4

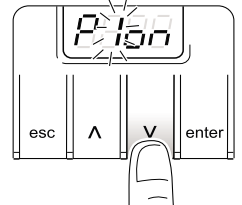

5

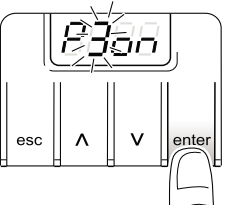

6

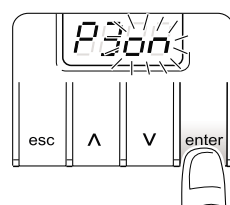

7

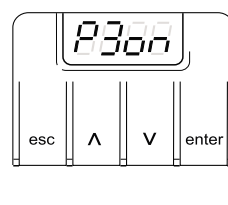

8

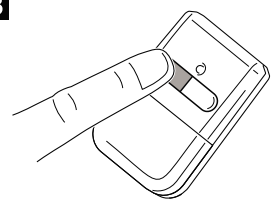

9

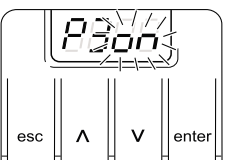

10

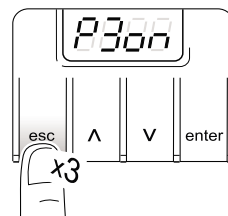

11

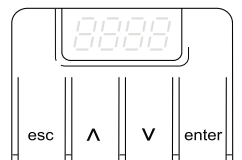

1 انتظر بينما يقوم القضيبي بالمسارات.

جدول البرمجة الكامل

الخيارات أو القيم	خيار مُحدّد مسبقاً	D4	D3	المُتغيّر	D2	D1
	x	1	0	اتجاه دوران المُحرّك	1	C
		2	0			
مُعطل					4	
جهاز غير مُثبت	x	0	0	جهاز أمان الإغلاق (خلية صوتية أو شريحة)	5	
جهاز بدون اختبار		0	1			
جهاز مُختبر		1	1			
		n	0	تسجيل شفرة الراديو لفتح كامل	1	P
مُعطل					2	
		n	0	تسجيل مسار القضيّب	3	
آلي		1	0	نمط العمل	1	F
شبه آلي	x	2	0			
59 = 59 ثانية ، 2.5 = دقيقتان و 50 ثانية ، إلخ	15	9...0	5...0	زمن الانتظار في الوضع الآلي	2	
مُعطل					3	
بدون إنذار مُسبق	x	1	0	مصباح وامض	0	R
بإنذار مُسبق		2	0			
59 = 59 ثانية ، 2.5 = دقيقتان و 50 ثانية ، إلخ	03	9...0	5...0	زمن إضاءة الجراج	1	
أ: أدنى سرعة ، ب: أقصى سرعة	03	5...1	0	سرعة القضيّب	2	
أ: أدنى سرعة ، ب: أقصى سرعة	02	5...1	0	السرعة خلال التوقّف المتباطئ	3	
أ: أدنى مسافة ، ب: أقصى مسافة	00	5...0	0	مسافة التوقّف المتباطئ	4	
مُعطل					5	
أ: أدنى قوّة دفع ، 10 : أقصى قوّة دفع	05	9...0	1...0	أقصى قوّة دفع	6	
إغلاق فوري		1	0	مرور عبر خلية إغلاق صوتية خلال زمن الانتظار (فقط في الوضع الآلي)	7	
إعادة تعيين زمن الانتظار	x	2	0			
بدون تأثير		3	0			
إغلاق فوري		1	0	تشغيل زر الكهرباء خلال زمن الانتظار (فقط في الوضع الآلي)	8	
إعادة تعيين زمن الانتظار	x	2	0			
بدون تأثير		3	0			
فتح حسب النمط المُختار في الوظائف الرئيسية (F)	x	1	0	نمط الفتح	9	
فتح مُشترك (خلال الفتح لا تتبع لوحة التّحكّم أوامر الحركة)		2	0			
فتح تدريجي (لو أنّه خلال الفتح تم تشغيل أيّ جهاز حركة فإنّ القضيّب يتوقف. لو تم تشغيله من جديد فإنّ القضيّب يُغلق).		3	0			
يُشير إلى الدورات المنفّذة عن طريق ضرب الرّم المُحدّد في كميّة مُعيّنة ، على سبيل المثال: 68 يُحدّد 6.800 دورة مُنفّذة 6.8 يُحدّد 68.000 دورة مُنفّذة		x	x	عمليات مُنفّذة	1	0